



The Great Lakes - St. Lawrence Seaway System
Le réseau Grands Lacs - Voie maritime du Saint-Laurent

2015 - NOTICE TO SHIPPING #11

MAISONNEUVE REGION
MONTREAL/LAKE ONTARIO SECTION

Fall Protection Railings Eisenhower and Snell Locks

Railings will be installed at both U.S. locks this season as a fall protection measure for the Linehandlers.

Sections of railing 260 feet (79.2m) long will be installed at both ends of the lock chamber walls (north sides), just behind the lock wall coaming. (See attached drawing) The railings have been engineered to accommodate the mooring cable forces associated with a vessel lockage. The railings will be smooth and tapered to ensure non-obstructed transition of heaving lines and wires.

Once the railings are installed, embarking and disembarking procedures will change as follows:

For pilot exchanges and other such boardings, embarking and disembarking will take place mid lock chamber, where there is no railing. Boarding ramps have been modified to ensure boarding safety. Lock Operators will use a slow fill at these times, as required.

Maisonneuve Region
June 15, 2015

The St. Lawrence Seaway Management Corporation
Corporation de Gestion de la Voie Maritime du Saint-Laurent

Région Maisonneuve
151, rue de l'Écluse
St-Lambert, Québec
J4R 2V6

Tél : (450) 672-4115 Fax : (450) 672-8493

Niagara Region
508 Glendale Avenue
P.O. Box 370
St. Catharines, Ontario
L2R 6V8

Tel : (905) 641-1932 Fax : (905) 641-5721

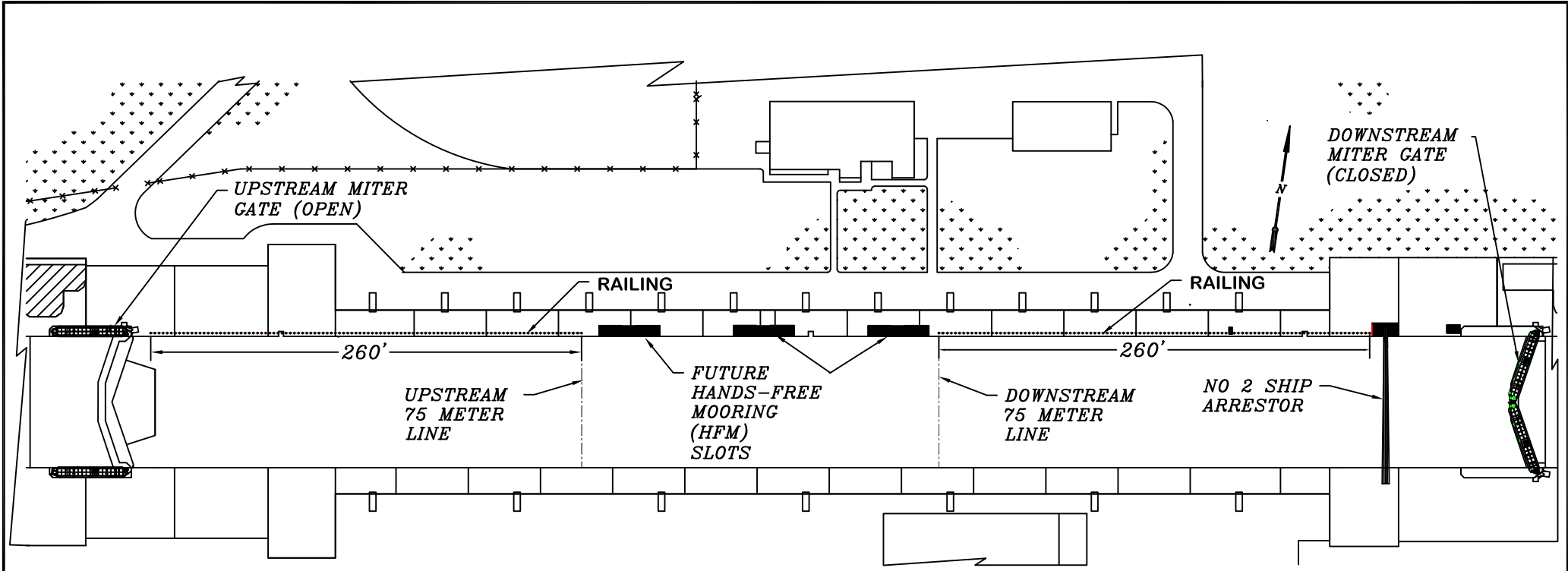

TYPICAL RAILING INSTALLATION ON NORTH LOCK WALL (EISENHOWER LOCK SHOWN).

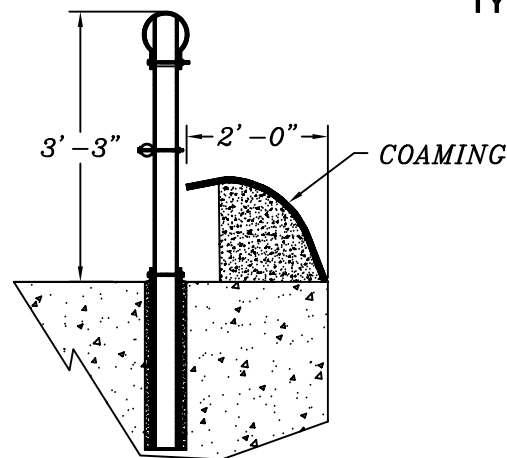

TYPICAL RAILING SECTION

*EISENHOWER & SNELL LOCKS
 FALL PROTECTION RAILING LAYOUT*
 NOT TO SCALE