

INFORMATION ON SHIP TRANSIT AND EQUIPMENT REQUIREMENTS

TABLE OF CONTENTS

| | |
|--|-----------|
| INTRODUCTION | 3 |
| GENERAL TRANSIT INFORMATION | 4 |
| 1. Traffic Control..... | 4 |
| 2. Pilotage Requirements | 4 |
| 3. Lock Communications | 4 |
| 4. Bridges (Canadian Sectors) | 5 |
| 5. Bridges - Signal Light System | 6 |
| 6. Ship Location Information..... | 7 |
| 7. Marine Weather Broadcasting and Data Collection..... | 7 |
| 8. Use of VHF Radio | 7 |
| 9. Fog..... | 7 |
| 10. Wind..... | 8 |
| 11. Hogging..... | 8 |
| 12. Approach Walls (Fendering)..... | 9 |
| 13. Ships with Bulbous Bows | 9 |
| 14. Meeting Areas | 9 |
| 15. Ships Operating in Restricted Channels..... | 10 |
| 16. Walk-through Procedures (Lock 8 - Welland Canal and Iroquois Lock - Montreal to Lake Ontario)..... | 10 |
| 17. Stern Anchor | 11 |
| 18. Water Level Information | 11 |
| 19. Anchor Marking Buoys | 14 |
| 20. Typical Landing Boom..... | 15 |
| 21. Embarking or Disembarking in Lock Chambers | 17 |
| 22. Bulwark Ladders..... | 17 |
| 23. Use of Portable Fenders | 17 |
| 24. Navigational Aid Deficiencies | 19 |
| 25. Typical Pedestal..... | 19 |
| 26. Fairleads | 20 |
| 27. Fenders | 23 |
| 28. Cargo Load Plan Example- Please Adapt to Suit Your Own Ship..... | 27 |
| 29. Block Diagrams | 28 |
| 30. Ballast Water Tank Information | 31 |
| NAVIGATION SIGNAL LIGHT SYSTEM | 32 |
| 1. General | 32 |
| 2. L/A Signs..... | 33 |
| 3. Lock Signal Light Panels | 34 |
| 4. Operation of Signal Light Panels..... | 34 |

| | |
|--|-----------|
| SHIP MANOEUVRES..... | 36 |
| 1. General | 36 |
| 2. Passing Entry | 36 |
| 3. Modified Passing Entry..... | 38 |
| 4. Passing Entry Where a Road Bridge Crosses Over One End of a Lock..... | 39 |
| TURNBACK LOCKAGE..... | 41 |
| 1. General | 41 |
| 2. Turnback for Upbound Ships..... | 41 |
| 3. Turnback for Downbound Ships | 42 |
| MOORING SHIPS | 43 |
| 1. Safety Precautions | 43 |
| 2. Mooring Lines..... | 44 |
| 3. Ship Mooring Locations..... | 44 |
| AMERICAN LOCKS..... | 45 |
| 1. Navigation Signal Light System..... | 45 |
| 2. Tie-up Walls | 46 |
| APPENDIX 1 SEAWAY MILEAGES TO PRINCIPAL LOCATIONS..... | 47 |
| APPENDIX 2 TABLE OF TRUE ORIENTATION - Canal Locks..... | 49 |
| APPENDIX 3 Free Drawing Review Service..... | 50 |
| APPENDIX 4 - Hand Lines..... | 51 |

INTRODUCTION

This section of the Seaway Handbook has been prepared to provide shipmasters and pilots with general transit and required equipment information for the St. Lawrence Seaway and is intended to complement the Practices and Procedures. The information herein contained does not supersede the Seaway Practices and Procedures.

The capacity of the Seaway system is limited principally by the locks and, in order to achieve maximum utilization of the facilities, a number of procedures, methods and special aids have been introduced.

Many of the subjects described in this section are designed to minimize the idle time at locks and to thus achieve the prime aim of minimizing round trip transit times for ships.

To achieve complete success in realizing our mutual goal, the full cooperation of masters, pilots and Seaway operations personnel is essential and is hereby requested.

If any additional information is required, you are asked to direct your inquiries to:

Marine Services

THE ST. LAWRENCE SEAWAY MANAGEMENT CORPORATION

202 Pitt Street
Cornwall, Ontario Canada
K6J 3P7

Tel.: (613) 932-5170

OR

Director, Office Lock Operations

GREAT LAKES ST. LAWRENCE SEAWAY DEVELOPMENT CORPORATION

Post Office Box 520
Massena, New York 13662 - 0520
U.S.A.

Tel.: (315) 764-3293

GENERAL TRANSIT INFORMATION

1. Traffic Control

The purpose of Seaway Traffic Control is principally to provide the safe and efficient scheduling of ships. Associated with this is the information service in connection with Search and Rescue, pilot scheduling and ship information to the shipping entities and the public.

Ship traffic in the Seaway is controlled from three main centres: one located in St. Lambert, Quebec, one in Massena, New York, and the other in St. Catharines, Ontario. The St. Lambert centre operates through two radio stations: Seaway Beauharnois and Seaway Iroquois. The Massena centre operates through three radio stations: Seaway Eisenhower (KEF), Seaway Clayton (WAG) and Seaway Sodus, while the St. Catharines centre operates through three stations: Seaway Welland, Seaway Newcastle and Seaway Long Point.

In each control centre the traffic controllers have a number of aids available to assist them in their work. Some of these aids are: computerization, closed circuit television, display boards and an extensive communications network.

2. Pilotage Requirements

Masters or agents of ships in ports or at docks wishing to order a pilot should do so directly via Landline communication with the nearest pilotage dispatch office.

Procedures regarding the reporting of pilotage requirements when in transit are described in the Seaway Regulations.

3. Lock Communications

Within the Montreal to Lake Ontario lock areas, mooring instructions between the lock operator and the ship is carried out via VHF radio using the following channels:

| | |
|----------------------------------|------------|
| Lock No. 1 - St. Lambert | Channel 17 |
| Lock No. 2 - Côte Ste. Catherine | Channel 13 |
| Lock No. 3 - Beauharnois | Channel 17 |
| Lock No. 4 - Beauharnois | Channel 13 |
| Lock No. 5 - Snell | Channel 17 |
| Lock No. 6 - Eisenhower | Channel 13 |
| Lock No. 7 - Iroquois | Channel 17 |

Note: At Canadian Locks, ships are advised to set their VHF radio to low power when using channel 13 or 17.

Within the Welland Canal lock areas, mooring instructions between the lock operator and the ship is carried out via VHF radio using the following channels:

| | |
|-------------------------|-------------|
| Lock No. 1 | Channel 75 |
| Lock No. 2 | Channel 76 |
| Lock No. 3 | Channel 77 |
| Lock No. 4, 5 & 6 West | Channel 15 |
| Lock No. 4, 5, & 6 East | Channel 17 |
| Lock No. 7 | Channel 66A |
| Lock No. 8 | Channel 77 |

Ships must also continue to monitor channel 14.

Ships must provide verbal acknowledgement of all mooring instructions via VHF radio.

The above system of communications is used solely for mooring instructions or in an emergency. All other radio communications must be directed to the appropriate Traffic Control Centres.

4. **Bridges (Canadian Sectors)**

V.H.F. transceivers fitted with Channel 14 have been installed at the following bridges: Kahnawake, St. Louis and Valleyfield in Sector 1 and Bridges 1, 3A, 4, 5, 11 and 21 on the Welland Canal. The use of these is limited to periods of reduced visibility and emergencies only. The radio call sign is the applicable bridge name or number, i.e.

``VALLEYFIELD BRIDGE, THIS IS SHIP ... or ``BRIDGE 11, THIS IS ...''

To further assist traffic and enhance safety during periods of reduced visibility, radar has been fitted at the following bridges: St. Louis, Valleyfield, in Sector 1, and Bridges 4, 11 and 21 on the Welland Canal. At the Valleyfield and St. Louis Bridges, vertical markers are installed on the centre line of the mobile spans. At night, the markers are floodlit.

Bascule Bridges: Ships with high raking counters, superstructures and/or flared bows which could overhang the top of lock walls when the ship is not parallel to the wall must exercise extreme care in navigating past bascule bridges. Bascule bridges impose restrictions on ship dimensions and, in this regard, specific reference is made to Seaway Regulation No. 3 and Appendix I.

At bridges 7A, 7B, St. Louis and Valleyfield in sector 1 and bridges 4,5,11 and 21 in the Welland Canal, when a ship has cleared the draw of the bridge, the bridge operator will communicate with the ship by VHF radio prior to initiating the closing/lowering of the bridge. The master/pilot of the ship is not required to call back unless a problem situation warrants it.

In case of a malfunction of the bridge or a power failure, a ship must not pass the limit of approach sign.

5. Bridges - Signal Light System

A system of navigation light signals and signs is in effect at all free-standing lift bridges in both the Montreal/Lake Ontario section and the Welland Canal.

The system includes:

- a) A red and green bridge navigation light display on the moveable bridge span
 - i) In the Welland Canal only, there is an additional yellow navigation light beside the red and green navigation lights.
- b) A limit of approach sign (L/A) - (red background, white letters, diamond shape)
- c) A caution sign equipped with amber lights - (yellow-black checkerboard, triangular shape)
- d) A whistle sign (yellow background - black lettering square shape).

The operation of the system is as follows:

1. When the ship's stem arrives at the **WHISTLE** sign, the **AMBER** lights on the **CAUTION** sign start to flash. This acknowledges that the bridge operator has seen the ship and will commence the bridge operation. The master shall signal the bridge if he does not receive a **FLASHING AMBER** light at this time.

NOTE: *At this time, the **RED BRIDGE NAVIGATION** light will be displayed on the bridge span.*

2. After the bridge operator acknowledges the presence of the ship at the **WHISTLE** sign, he will commence the bridge raising operation.

NOTE: *In the Welland Canal, a **YELLOW BRIDGE NAVIGATION** light will begin flashing when the process to raise the bridge has been initiated and the vehicle traffic lights are set to red. The **RED BRIDGE NAVIGATION** lights will remain on as usual.*

When the bridge starts to rise, the **RED BRIDGE NAVIGATION** lights will commence flashing.

NOTE: *In the Welland Canal, the **YELLOW BRIDGE NAVIGATION** lights will turn off when the **RED BRIDGE NAVIGATION** lights start flashing.*

3. When the ship's stem is abeam of the **CAUTION** sign and the **GREEN BRIDGE NAVIGATION** lights are displayed, the ship is allowed to proceed through the bridge draw. If, however, the **GREEN BRIDGE NAVIGATION** lights are not displayed at the time the stem of the ship is abeam of the **CAUTION** sign, the Master should take any action necessary to ensure that the ship does not pass the L/A sign before the bridge span is fully raised and

the **GREEN BRIDGE NAVIGATION** lights are displayed.

NOTE: *Under normal conditions the bridge span should be fully raised by the time the ship reaches the **CAUTION** sign.*

6. Ship Location Information

- a) **MONTREAL/LAKE ONTARIO SECTION:** The Regional Information Centre, Montreal, is responsible for providing to the public and shipping interests information relative to ship movements within the Montreal/Lake Ontario section. The telephone number is (450) 672-4115.
- b) **WELLAND CANAL AREA:** For information regarding the position of ships in and around the Welland Canal, the telephone number is (905) 688-6462.
- c) **ST. LAWRENCE SEAWAY:** Information on ship location is also available on the Seaway Web site at www.greatlakes-seaway.com, under navigation.

7. Marine Weather Broadcasting and Data Collection

- a) During the navigation season, general marine weather broadcasts will be routinely issued by the Canadian Coast Guard.
- b) *Ship Weather Data Stations*

Ships encountering adverse weather or sailing conditions are urged to notify the appropriate Seaway Control Centre giving pertinent information. This information will in turn be broadcast to other ships and relayed to the meteorological branch offices concerned.

8. Use of VHF Radio

The use of Seaway working frequencies as outlined in the Seaway Regulations is restricted to ship-to-shore (Ship Traffic Management) communications. Ship-to-ship communications must be carried out on the designated VHF channels. Strict adherence to these regulations is required.

9. Fog

The incidence of fog is most prevalent in the American Narrows, CIP 9 (*Richards Point*) to Light 41, west end of mooring cells above Eisenhower Lock, St. Regis Island to Grasse River below Snell Lock, in the vicinity of the Valleyfield Bridge and in the upper reach of the Welland Canal.

In the American Narrows, navigation will be suspended when the visibility is 1/2 mile or less. High intensity strobe lights have been installed at the lower wall of Snell Lock and the upper wall at Eisenhower lock to assist ship masters in locating the wall in times of poor visibility.

In Canadian waters, navigation will be suspended by the Traffic Control Centre when visibility becomes insufficient to permit safe navigation. In general, navigation will be suspended when visibility falls to less than a ¼ M, except in the Beauharnois Canal where two-way navigation will be permitted until visibility falls to ¾ M, at which point navigation will be suspended. Ships downbound under conditions of reduced visibility must have a competent crew member in attendance at the stern anchor when approaching bridges.

In some locations, under certain conditions, one-way navigation will be permitted when visibility is between ¼ M and ½ M. In these cases, ships will be asked to proceed by invitation only.

When fog is forecast, ships may be assembled in anchorages or on approach walls or wharves to permit localized operation during the period when navigation is suspended elsewhere.

A strobe light is located on the approach wall above the upper Beauharnois Lock and above Iroquois Lock.

10. Wind

When high winds prevail, or are forecasted, ships are permitted to transit in accordance with established wind scales which take into account wind velocity and direction, ship draft and exposed "sail area" and operating bow thrusters. The scales serve as guidelines in scheduling ship traffic at Seaway structures under adverse wind conditions.

- NOTE:** 1) *When a ship becomes windbound in a Traffic Sector, it is essential that it be moored or anchored in a location which does not prevent the safe manoeuvring of other ships that are able and allowed to transit.*
- 2) *Under conditions of wind or low visibility ships are not normally kept in lock chambers.*

11. Hogging

During hot summer weather, the heat radiated by the sun causes expansion of the exposed deck area, while the lower plates which are submerged remain comparatively cool. The expansion of the upper deck results in a bending effect commonly known as "hogging". This "hogging", particularly in the case of ships with a large expanse of open deck, may increase the "fore and aft" draft by as much as 13 cm and create an overdraft condition.

Masters, aware of this possibility, usually take the precaution of running water over the deck during daytime periods of extreme heat.

It is recommended that masters of ships with a large expanse of open deck take the precaution mentioned above to prevent deck expansion and avoid delays while adjusting drafts.

12. Approach Walls (Fendering)

Approach walls are situated above and below all locks to assist ships entering the locks and also for securing while awaiting their turn for the lock. Rubber fendering is provided at various locations to facilitate ship entry.

In the Welland Canal, pneumatic fender units are located at the east and west wall transition points immediately below Lock 7 to facilitate ship entries and exits at this lock.

13. Ships with Bulbous Bows

Certain lock approach walls are supported by timber or concrete piles. It has been found that extensive damage is occurring to this timber piling. It is reported that ships with bulbous bows may be causing this damage when the angle of approach to the wall is too great. Mariners are therefore requested to keep the angle of approach as small as possible, consistent with the safety of the ship, and to advise the nearest Seaway radio station immediately if they suspect the bulbous bow may have contacted the pilings of an approach wall.

14. Meeting Areas

Due to restricted channel width in the Welland Canal from former Bridge 10 Piers to Mile 11.3 (overhead power line crossing), only ships with a combined beam of less than 30 m will be initially dispatched to meet in this area. Exceptions may arise when, for example, a downbound ship finds herself close to Mile 11.3 while an upbound ship, because of slow transit, is just through the draw of Bridge 11. Another exception may be made when the Masters of both upbound and downbound ships request that they be permitted to meet.

Guard Gate Cut (Buoys WC31 to WC33)

Due to restricted channel width this area is a no meeting area.

Port Colborne Harbour

When ships are dispatched to meet in Port Colborne Harbour, each ship will be notified of the name, dimensions and load condition of the opposing ship.

15. Ships Operating in Restricted Channels

When using restricted channels ships are subjected to certain conditions which are normally not found when transiting wide rivers, lakes or other water expanses. Of importance are the following conditions and Masters should take these into account when sailing in restricted channels:

- (a) Bank Suction
- (b) Ship Meeting
- (c) Squat

- a) **BANK SUCTION** - A ship sailing in the proximity of one of the banks of a channel will experience bank suction forces, which are caused by the asymmetrical flow of water around the ship. The closer a ship nears a bank the larger the bank suction forces become. It is therefore important that ships do not get too close to any of the banks.
- b) **SHIP MEETING** - Hydrodynamic interaction will take place between two ships meeting or passing each other, either going in the same direction or in opposite directions. The interaction forces and moments on the ships will cause course deviation and yaw to occur. It is important that ships maintain adequate separation when passing or meeting. At present there is insufficient information to determine a "safe" separation distance based on ship size, speed, rudder activity, etc. However, for ships meeting, it is considered that a separation of half the combined beam width of the ships should provide a safe minimum distance. For ships overtaking, the Ministry of Transport recommends a separation of not less than one to two beam widths of the larger ship.
- c) **SQUAT** - A ship moving through the water will generate pressure forces that will bring a reduction in the water level and cause the ship to sink bodily in the water and change its trim. Generally, depending on initial trim, full-bodied ships trim down by the bow and slender ships down by the stern.

Squat increases proportionally with the length of the ship and with the square of the forward speed.

In general, the speed limits, which have been established in Seaway waters, take into account squat conditions. Apart from other considerations, it is therefore important that ships operate within the established speed limits.

16. Walk-through Procedures (Lock 8 - Welland Canal and Iroquois Lock - Montreal to Lake Ontario)

When water conditions permit, a walk-through procedure may be used at Lock 8 – Welland Canal or at Iroquois Lock – Montreal to Lake Ontario section.

With this procedure, a ship passing through the lock will not be required to secure in the lock but will proceed under her own power at a speed consistent with safety.

The ship must have personnel ready at mooring stations with mooring lines ready for deployment in the event they are required, at Iroquois Lock.

17. Stern Anchor

Ships required by Seaway Regulation No. 15 to be equipped with a stern anchor must ensure it is properly rigged and available for use throughout the Seaway transit.

Every ship of more than 125 metres (410 feet) overall length whose keel is laid after January 1, 1975 shall be equipped with a fully operational stern anchor suitably rigged for immediate release, holding and retrieving.

The stern anchor shall be arranged to the satisfaction of the ship's Classification Society or National Authority. The anchor shall have a weight of not less than 50% of the Classification Society's or National Authority's rules for the ship's bower anchor and the length of cable to suit the anchor shall not be less than 110 metres (60 fathoms).

Wire cable may be used but it shall be of the same tensile strength as the chain cable required for the anchor, and the first fathom attached to the anchor shackle shall be chain cable. The wire cable shall be attached to a windlass. However, the anchor may be attached to a power-operated winch drum, provided it has the same strength as that required of an anchor windlass and can perform the same function as an anchor windlass.

The anchor windlass or power-operated winch drum must be capable of retrieving the anchor at a mean speed of 9 metre per minute and be capable of retrieving the anchor with 80 metre of chain cable or wire cable.

If the ship's spare bower anchor is to be used as a stern anchor, then the chain cable should have a minimum strength of not less than 60% of that required for the bower anchor.

18. Water Level Information

- (1) Water level information is available on the Seaway website (www.greatlakes-seaway.ca) under "Commercial Shipping"
- (2) Current water levels are also broadcast via AIS for various water level stations throughout the Seaway.
- (3) Tele-announcers are also installed at various locations. Water level information can be obtained from these locations by dialling:

| | |
|---------------------------|---|
| Summerstown | 1-613-931-2089 <i>(English or French)</i> |
| Morrisburg | 1-613-543-3361 <i>(English or French)</i> |
| Iroquois Lock - Upper End | 1-613-652-4426 <i>(English or French)</i> |
| Brockville | 1-613-345-0095 <i>(English or French)</i> |
| Kingston | 1-613-544-9264 <i>(English or French)</i> |
| Port Weller | 1-905-646-9568 <i>(English or French)</i> |
| Port Colborne | 1-905-835-2501 <i>(English or French)</i> |

The telephone will ring briefly and an announcement will be heard. Levels provided are in reference to chart datum.

- (4) The following chart provides the chart datum for the various water level gauges along the Seaway:

MLO Section of the Seaway

| Station ID | Station Name | Chart Datum at Water Level Station (IGLD85) |
|-------------------|--|--|
| SLBL | ST. LAMBERT LOCK LOWER WALL | 5.35 |
| SLBU | ST. LAMBERT LOCK UPPER WALL | 10.66 |
| W-LAP | LAPRAIRIE | 10.66 |
| C_SCL | COTE STE. CATHERINE LOCK LOWER WALL | 10.66 |
| CSC | COTE STE. CATHERINE LOCK UPPER WALL | 20.29 |
| W-SSC | WATER LEVEL SOUTH SHORE CANAL ENTRANCE | 20.29 |
| BO3L | LOCK 3 BEAUHARNOIS LOWER WALL | 20.50 |
| W-BOH | BOH POOL LEVEL | 33.05 |
| BO4U | LOCK 4 BEAUHARNOIS UPPER WALL | 44.66 |
| W-SLU | WATER LEVEL ST. LOUIS BRIDGE | 45.18 |
| W-VAL | VALLEYFIELD LEVEL | 45.67 |
| CTL | CÔTEAU LANDING | 46.01 |
| SMT | SUMMERSTOWN | 46.24 |
| COW | CORNWALL ON | 46.40 |
| SNLL | SNELL LOCK LOWER WALL | 46.60 |
| W-SNLU | UPPER SNELL LEVEL | 60.45 |
| IKEL | EISENHOWER LOCK LOWER WALL | 60.45 |
| IKEU | EISENHOWER LOCK UPPER WALL | 72.50 |
| W-LGS | LONG SAULT LEVEL | 72.50 |
| W-MOR | MORRISBURG ON - MUNICIPAL DOCK | 72.86 |
| W-WAD | WADDINGTON LEVEL | 72.86 |
| IROL | IROQUOIS LOCK LOWER WALL | 73.18 |
| IROU | IROQUOIS LOCK UPPER WALL | 73.24 |
| CAR | CARDINAL ON | 73.50 |
| OGD | OGDENSBURG N.Y. | 73.88 |
| KGN | KINGSTON | 74.20 |

Welland Canal

| Station ID | Station Name | Chart Datum at Water Level Station (IGLD85) |
|------------|--|---|
| W-PWH | Port Weller Harbour - Welland Canal | 74.20 |
| L1N | Lock 1 Lower Wall | 74.17 |
| L1S | Lock 1 Upper Wall | 87.74 |
| RCH1 | Reach 1 (20-minute min of L2N) | 87.74 |
| L2N | Lock 2 Lower Wall | 87.74 |
| L2S | Lock 2 Upper Wall | 101.91 |
| RCH2 | Reach 2 (40-minute min of L3N) | 101.91 |
| L3N | Lock 3 Lower Wall | 101.91 |
| L3S | Lock 3 Upper Wall | 116.08 |
| RCH3 | Reach 3 (20-minute minimum of W-B05) | 116.08 |
| RCH6 | Reach 6 (20-minute min of L7NE) | 158.36 |
| L7NE | Lock 7 Lower East Wall | 158.36 |
| L7SE | Lock 7 Upper East Wall | 173.33 |
| LLVL | Long Level (60-minute min of L8NE) | 173.33 |
| L8NE | Lock 8 Lower East Wall | 173.33 |
| L8SE | Lock 8 Upper East Wall | 173.50 |
| W-PCH | Port Colborne Harbour, (60-minute min of L8SE) | 173.50 |

Example of calculation for water elevation, based on tele-announcer reading:

EXAMPLE

| | |
|-------------------------------|-----------------|
| (Reading from tele-announcer) | 0.74 m |
| (Datum for Summerstown) | <u>+46.24</u> m |
| Water Level (IGLD85) = | 46.98 m |

OR

(46.98 x 3.2808) = 154.13 feet IGLD85

19. Anchor Marking Buoys

Seaway Regulation 14 requires the installation of a highly visible anchor marking buoy on each anchor. Anchor buoys are to be attached and ready to deploy without any manual intervention. A soft line of at least 23 meters length shall connect the steel wire rope with the anchor marking buoy

Example

To hold the line in place near the ship's railing or bulwark is permitted. The steel wire rope shall be used for the section of the assembly within the hawse pipe, looped through the anchor chain and connected to itself with a shackle.

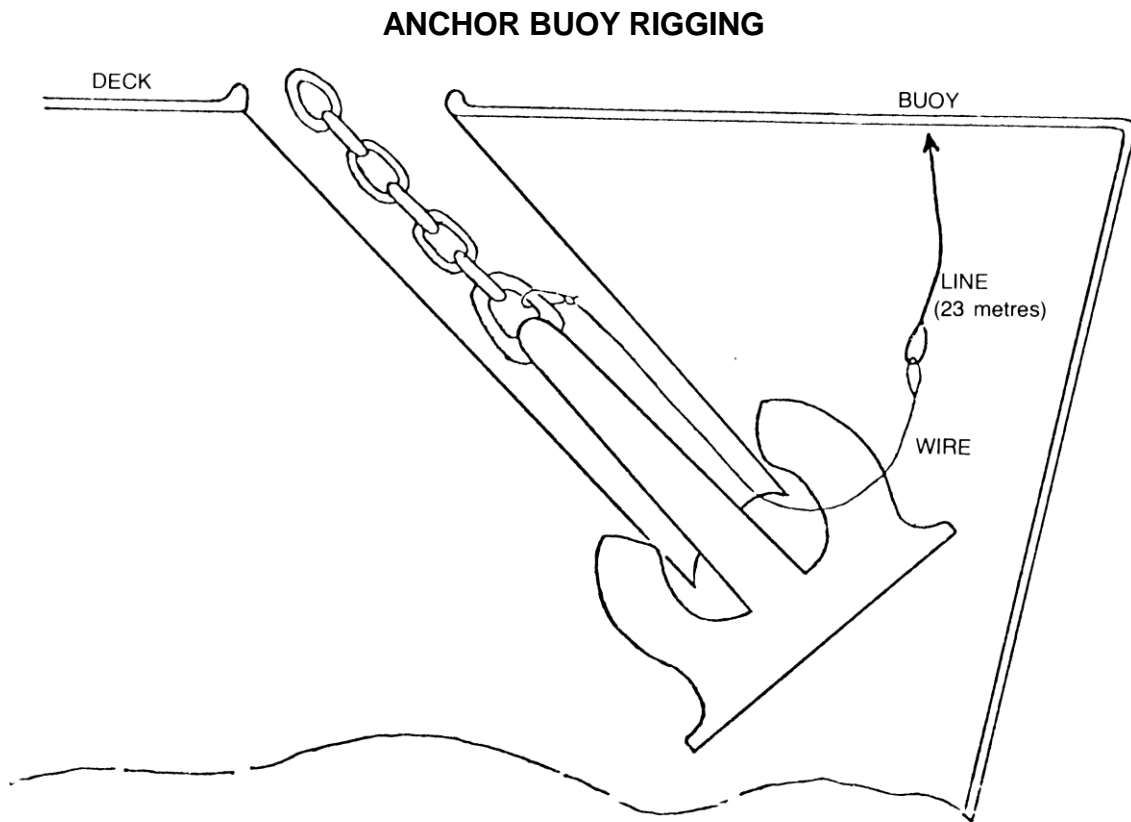

TYPICAL ANCHOR BUOYS

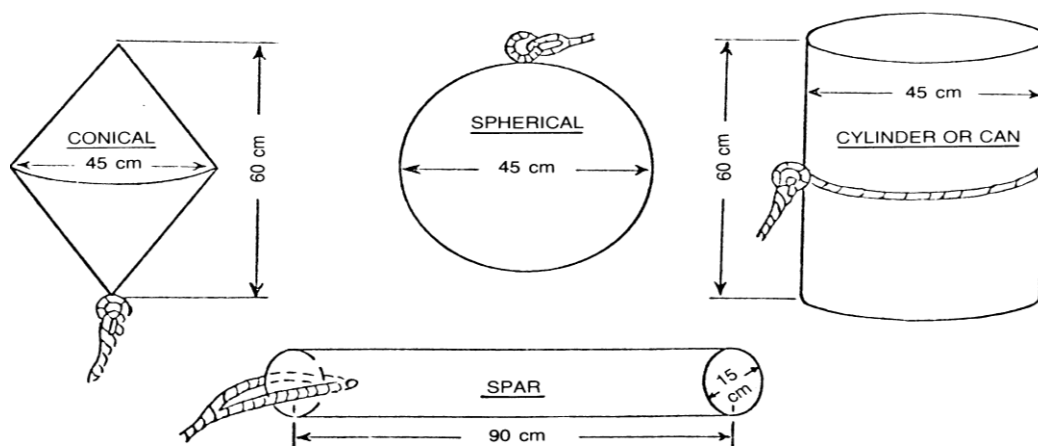

NOTE: The stowing of the anchor buoy in the hawse pipe is also acceptable.

20. Typical Landing Boom

Seaway Regulation 8 refers to ships of more than 50 m in overall length equipped with at least one landing boom on each side. It is recommended that a minimum Safe Working Load (SWL) of 227 kilograms be used for the landing booms.

Rigging of Landing Boom

It is important that the landing booms be maintained in good working condition at all times. It is suggested that prior to the first transit of each season, and at regular intervals the landing boom and associated equipment be cleaned and greased. Equipment should be checked for wear, tightened and adequately "moussed", spans, guys and landing ropes checked for deterioration and broken strands. Any doubtful items of equipment should be renewed immediately.

Landing booms must be capable of swinging outboard on their own from aft to forward. To facilitate this, the kingposts are usually canted outboard one to two degrees. An opening in the deck railing or bulwark is required if other suitable arrangements such as "Bulwark Ladders" (article 22) are not available for when the crew members have to swing outboard from the deck.

EXAMPLE

SUGGESTED LOCATION OF LANDING BOOMS

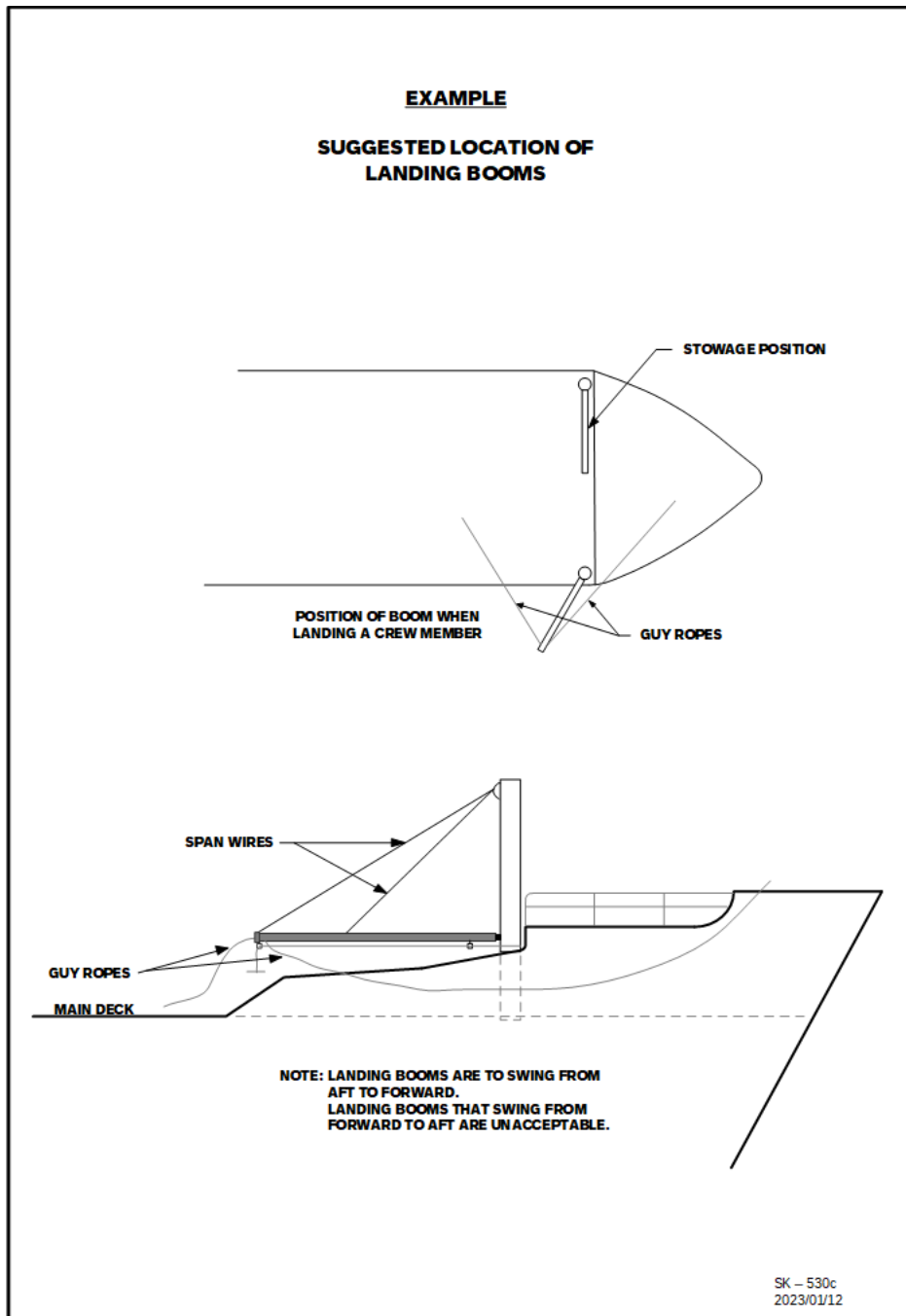

On completion of any new installation or the completion of each overhaul, the boom should be test swung with an adequate static load to ensure the integrity of all working parts. It is recommended that a timber safety block, with sufficient length of line for it to be lowered to the waterline at light draft, be stowed in close proximity to each boom, ready for immediate use.

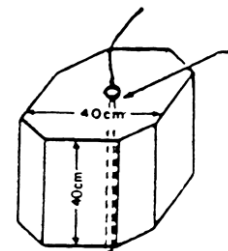

Safety Block

21. Embarking or Disembarking in Lock Chambers

It is important that safe working practices are followed for embarking or disembarking in Seaway locks. This should only be carried out when the ship is right alongside the lock wall, and crew member confirms with Captain that the ship is fully secured in the lock with Hands-Free mooring or with mooring lines . Crew members must not board or land from the ship between the two forward or the two after lines. Furthermore, they should not step over the mooring lines.

If there is a difference in height between the deck of the ship and the lock wall, a ladder should be used and a crew member should assist the person boarding or disembarking. At no time should one attempt to disembark by jumping from the ship.

22. Bulwark Ladders

For the safety of persons using bulwark ladders to board or disembark from a ship, Masters must assure that such ladders are secure. Hand-hold stanchions which do not form part of the ladder must be secured rigidly to the bulwark or the ship's rail. In cases where the stanchions and/or hand rails do form part of the ladder, the ladder itself must be secured firmly to the ship's structure.

23. Use of Portable Fenders

Masters should note that the successful use of portable fenders depends on their careful handling.

EXAMPLE

**GUIDELINES FOR
PORTABLE WOODEN FENDERS**

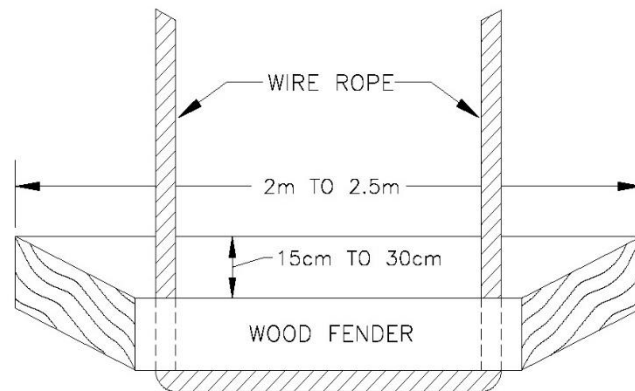

SK - 496c
2005/01/24

24. Navigational Aid Deficiencies

Navigational aid deficiencies in the Canadian and U.S. waters of the Seaway shall be reported to the Seaway Traffic Control Centres for transmission to the appropriate Coast Guard Traffic Centre.

25. Typical Pedestal

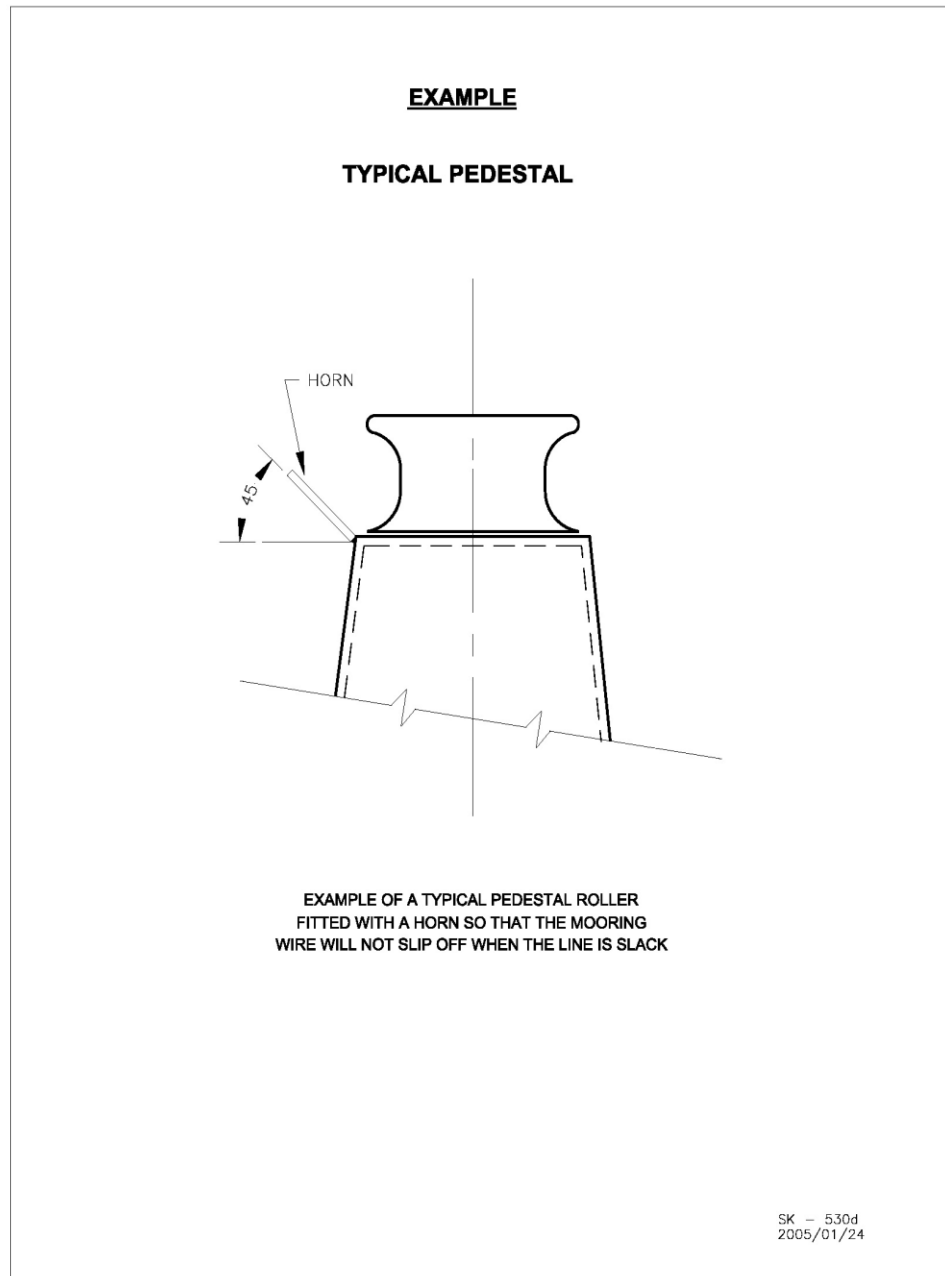

26. Fairleads

a) Typical Double Fairlead (for 2 wires)

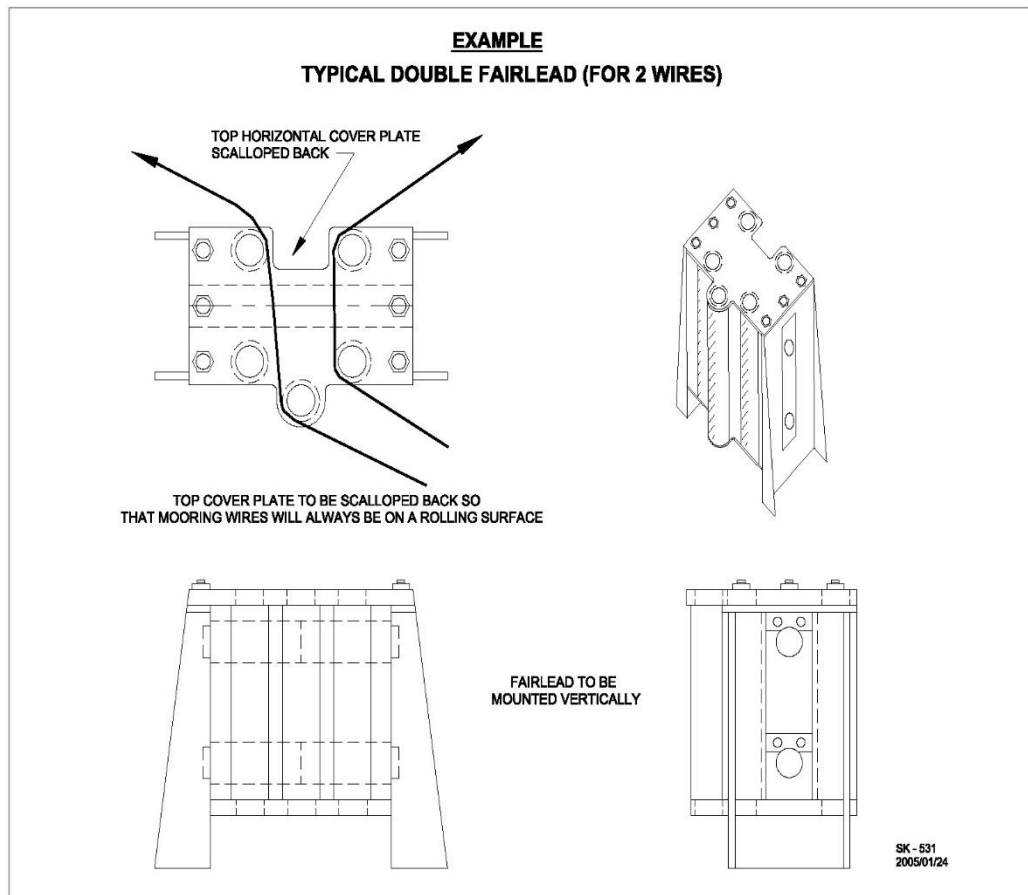

b) Example of When the Fairlead Follows the Bow Flare and the Fairleads are Full Beam

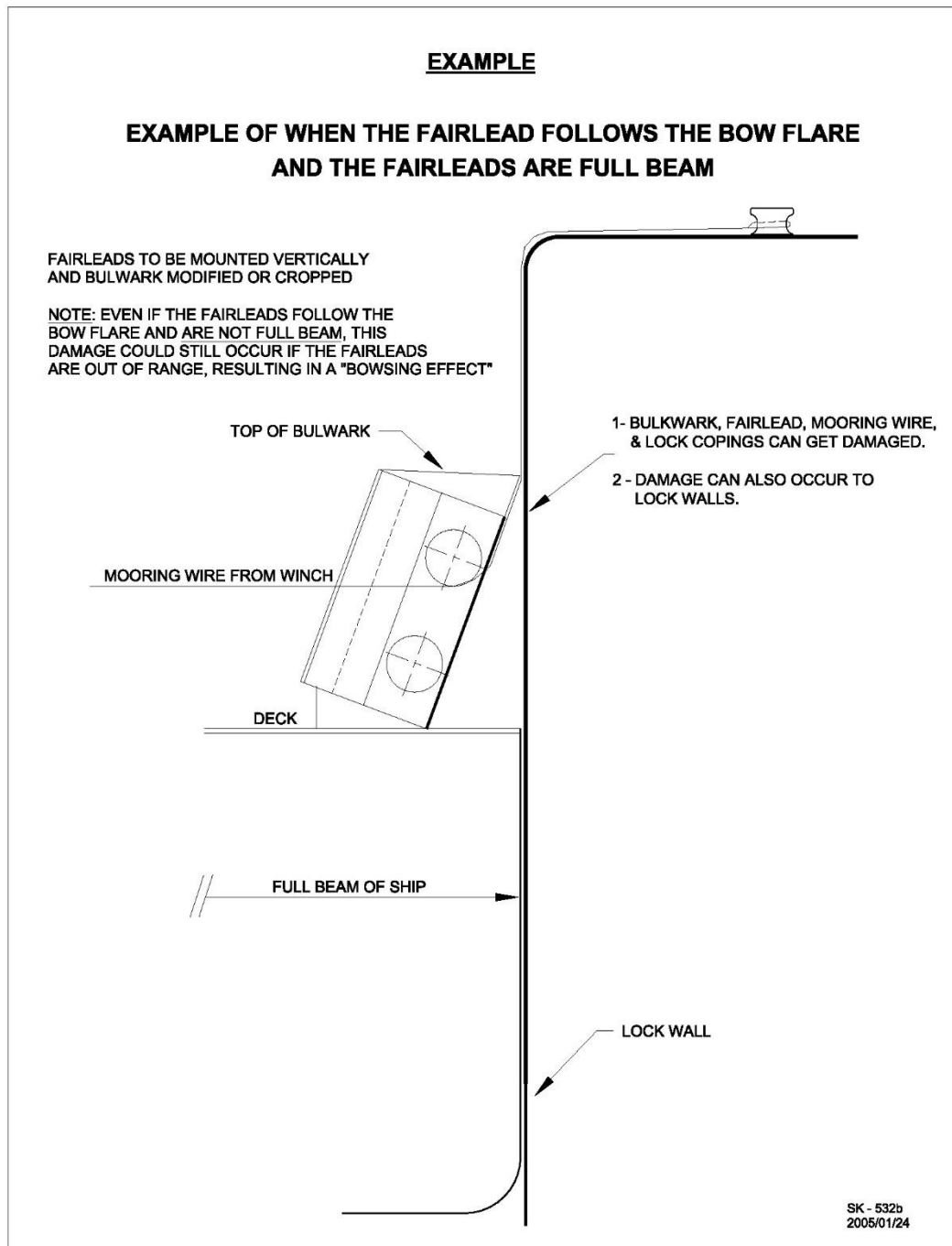

c) Typical Double Fairlead (for 2 wires)

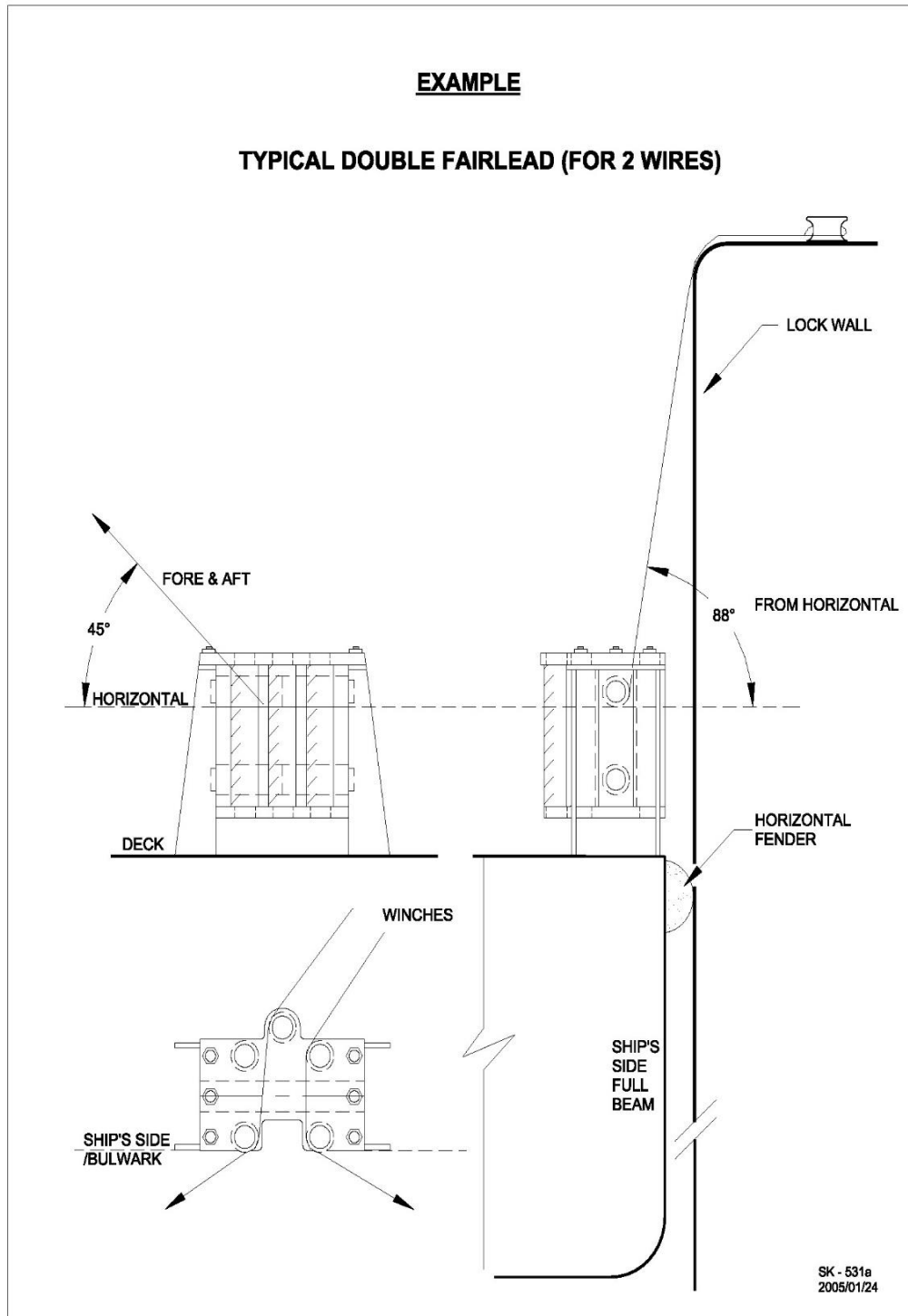

27. Fenders

a) General Arrangement for Fender Locations

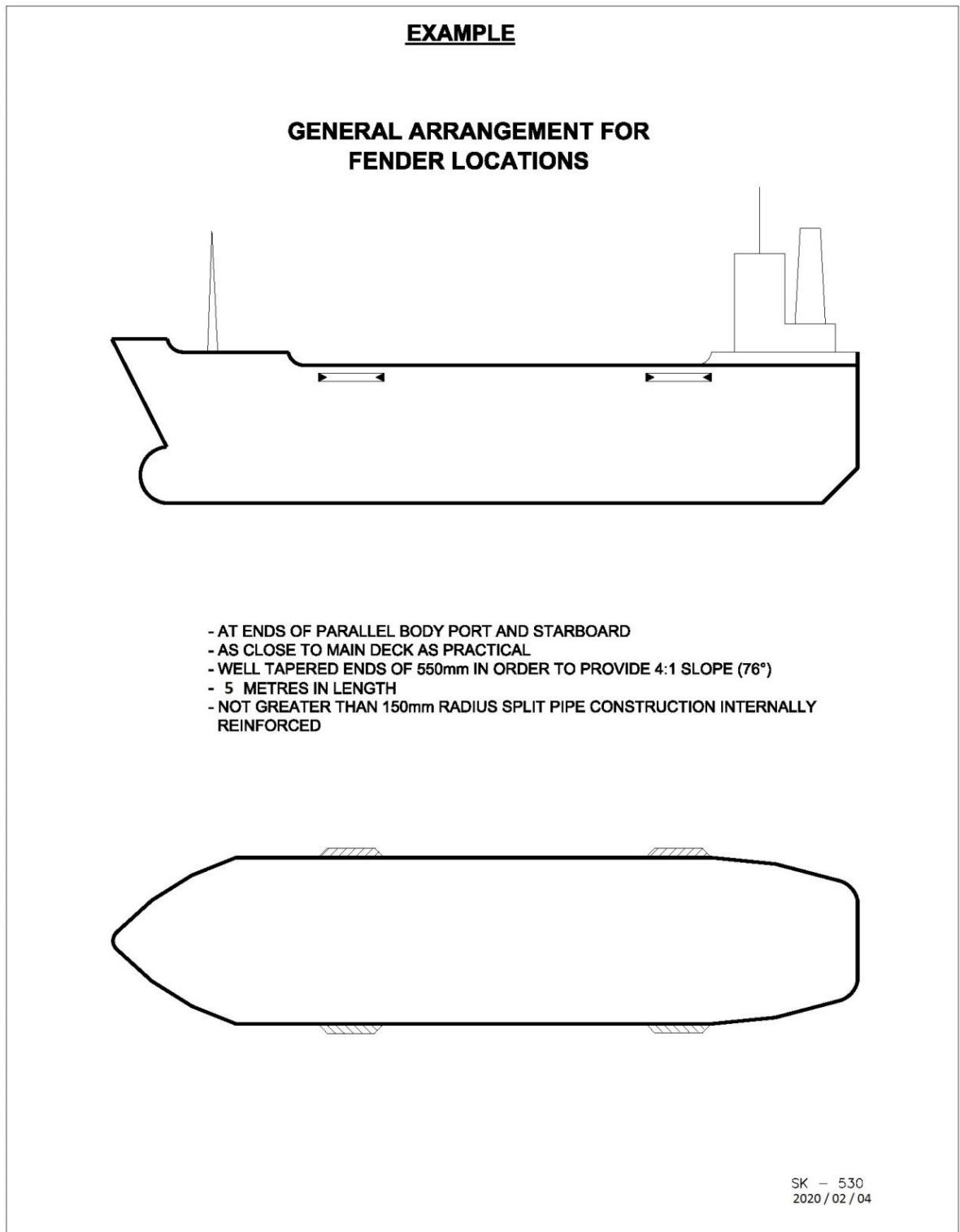

b) Guidelines for Fitting Permanent Steel Fenders

EXAMPLE

**GUIDELINES FOR FITTING
PERMANENT STEEL FENDERS**

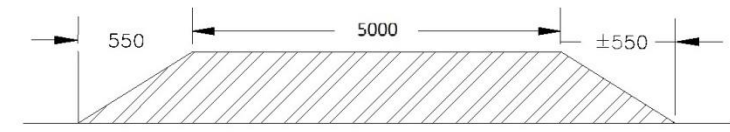
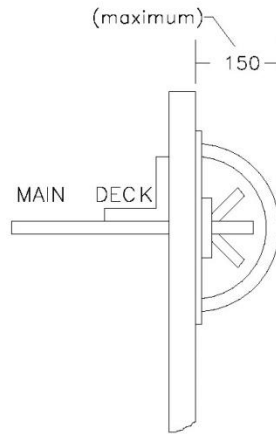

ALL DIMENSIONS ARE IN MILLIMETRES

SK - 496
2020 / 02 / 04

c) Half Round Solid Bar Design Below Main Deck

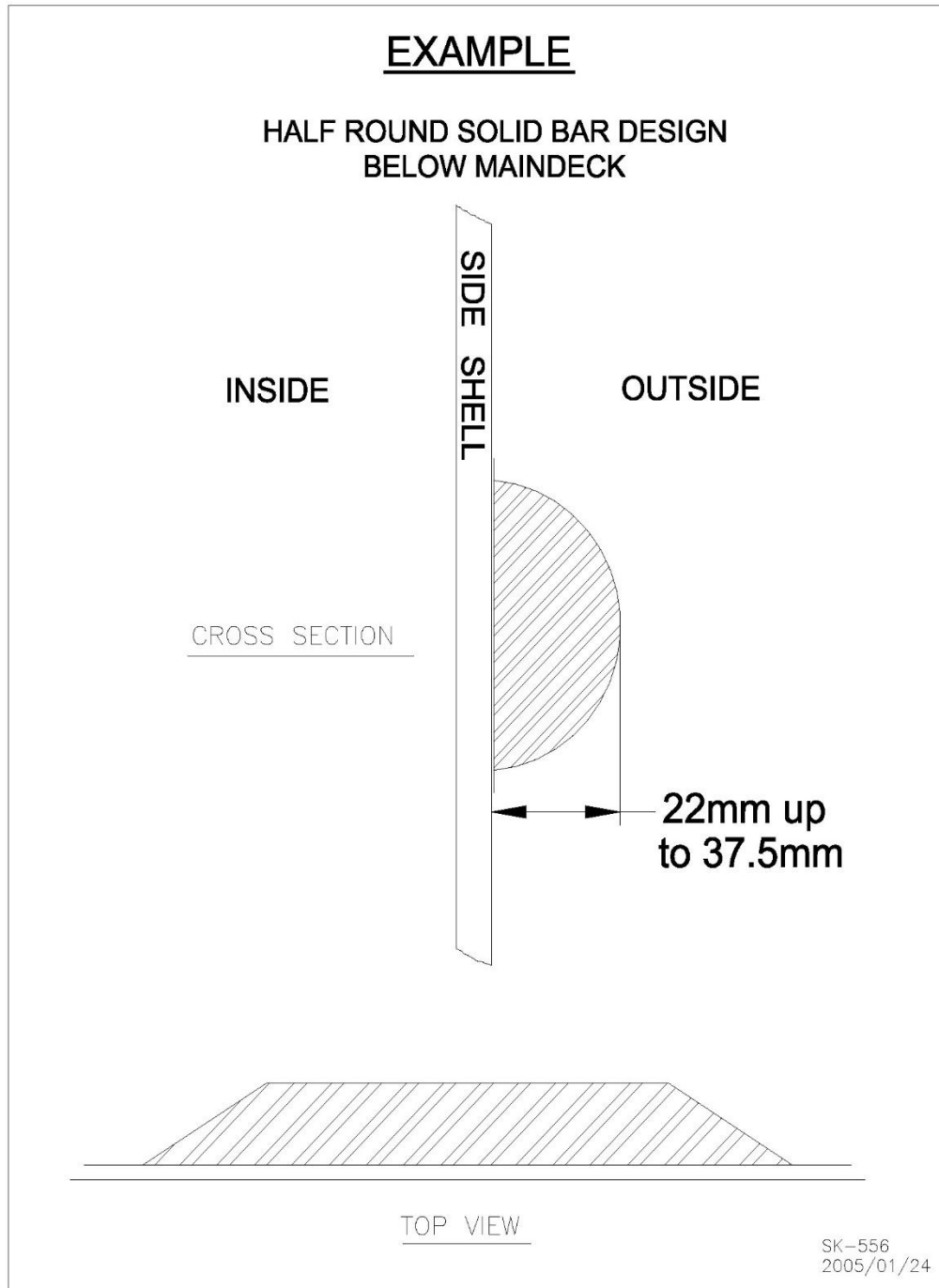

d) Flat Bar Rubbing Strip Design Below Main Deck

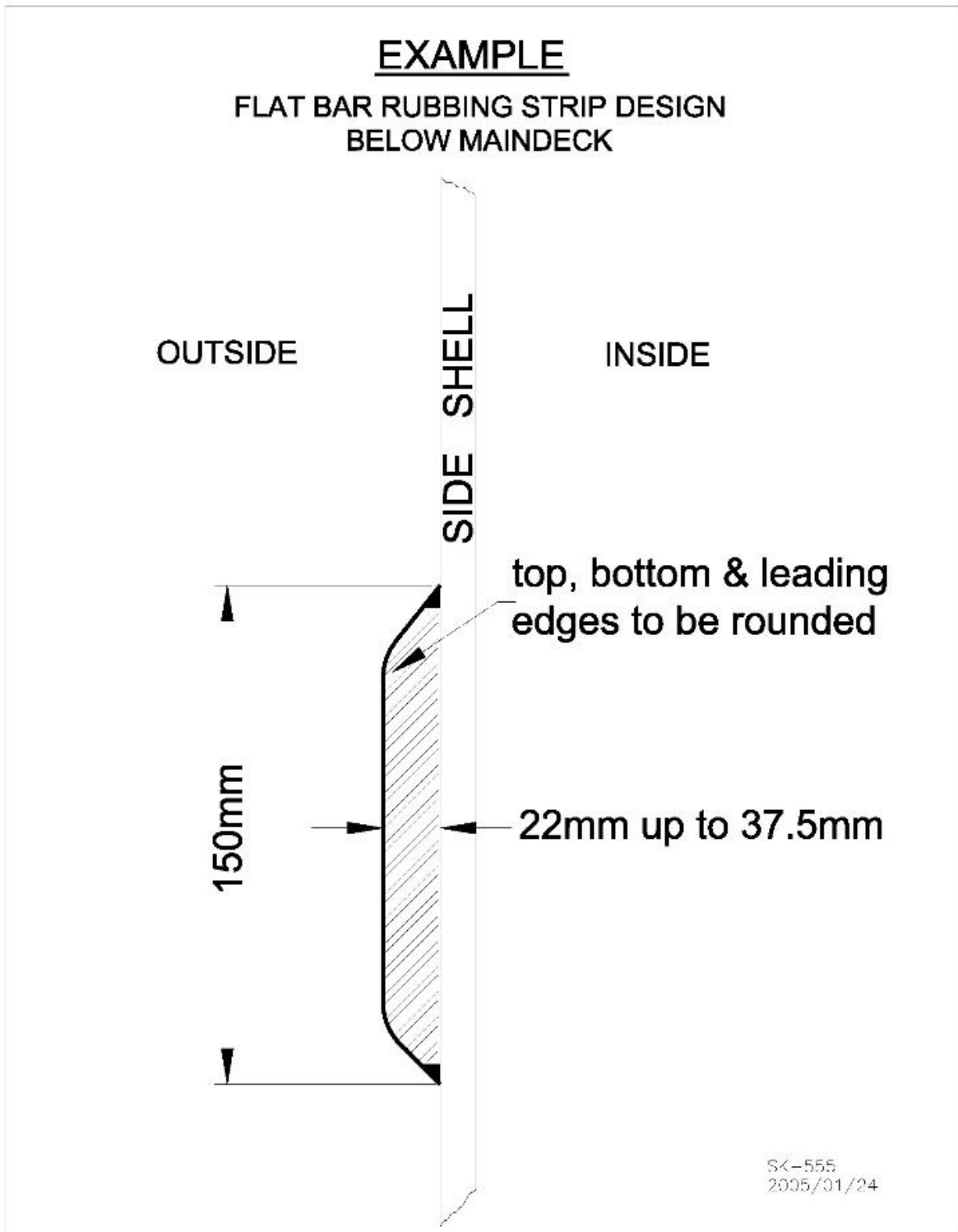

28. Cargo Load Plan Example- Please Adapt to Suit Your Own Ship

Owner's / Agent's Name:
Address:

Phone No:

Seaway Practices & Procedures no 72 – Reporting Dangerous Cargo

- St. Lambert, Qué.: Email: cdo@seaway.ca
 Massena, N.Y.: Email: vtc@dot.gov
 St. Catharines, Ont.: Email: nrerie@seaway.ca

CARGO LOAD PLAN

Ship's Name:

Date:

Time:

Cell:

Voyage No:

Port of Origin:

Next port:

Draft Fwd. / Aft: Fwd: _____

Aft: _____

ETA – St. Lawrence Seaway System

Please indicate only one arrival location

St. Lambert / Cape Vincent / Port Weller / Port Colborne

Date:

Time:

Loaded

Ballast

Gas free Yes No

Transverse Midship Section

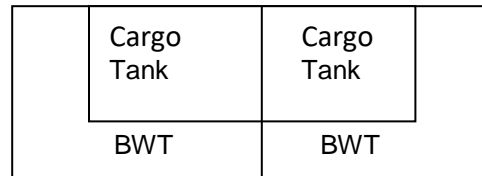

General Layout

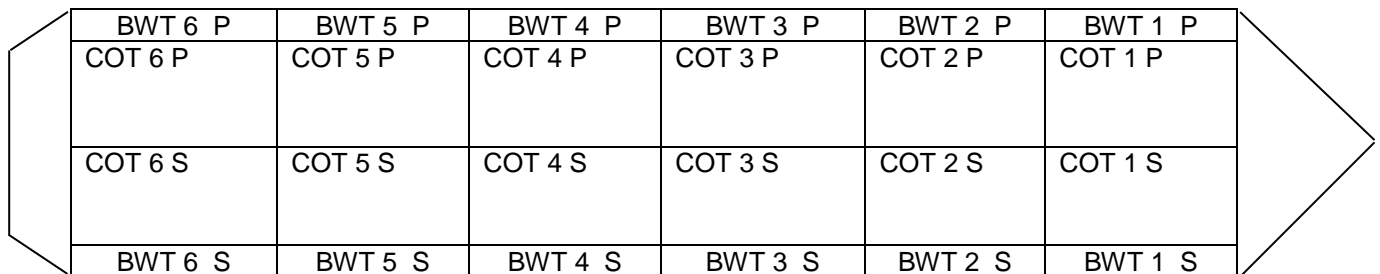

| Cargo <i>Previous Cargo if in Ballast</i> | Location – COT | Quantity | | IMO Class | UN No: | CDC Yes/No | Flash Pt. |
|--|----------------|----------|-------|-----------|--------|---------------|-----------|
| | | Cu. m | m / t | | | | |
| | - P & S | | | | | | |
| | | | | | | | |
| | | | | | | | |
| | | | | | | | |
| | | | | | | | |
| | Total | | | | | | |

Master: _____

Date: _____

29. Block Diagrams

a) Block Diagram – Bridge Wings Encroachment

29a - Appendix 1 - Block Diagram
Bridge wings encroachment

Example

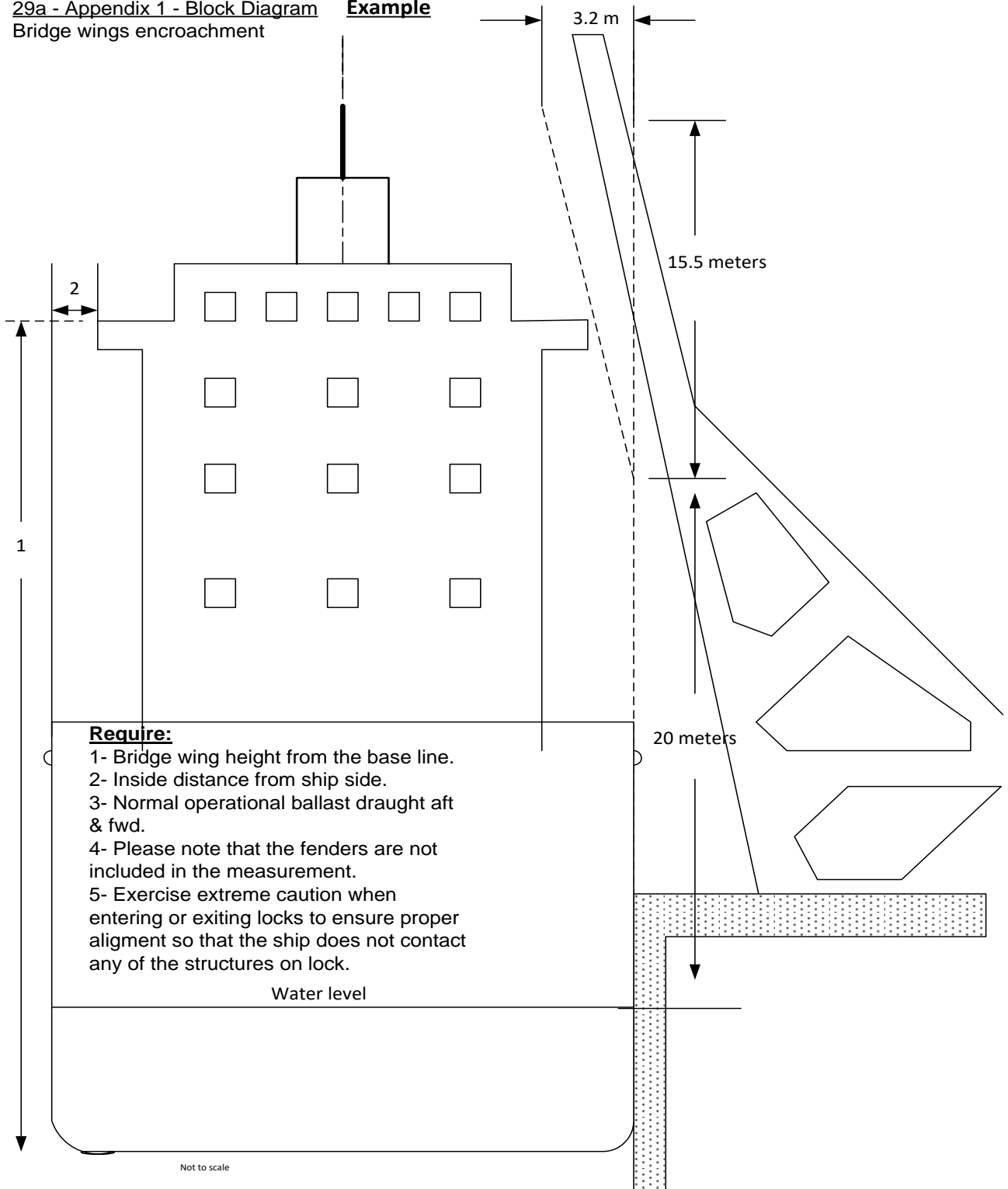

b) Block Diagram – Crane Position

29b - Appendix 1 - Block Diagram - Crane working position versus crane in stowed position
Example

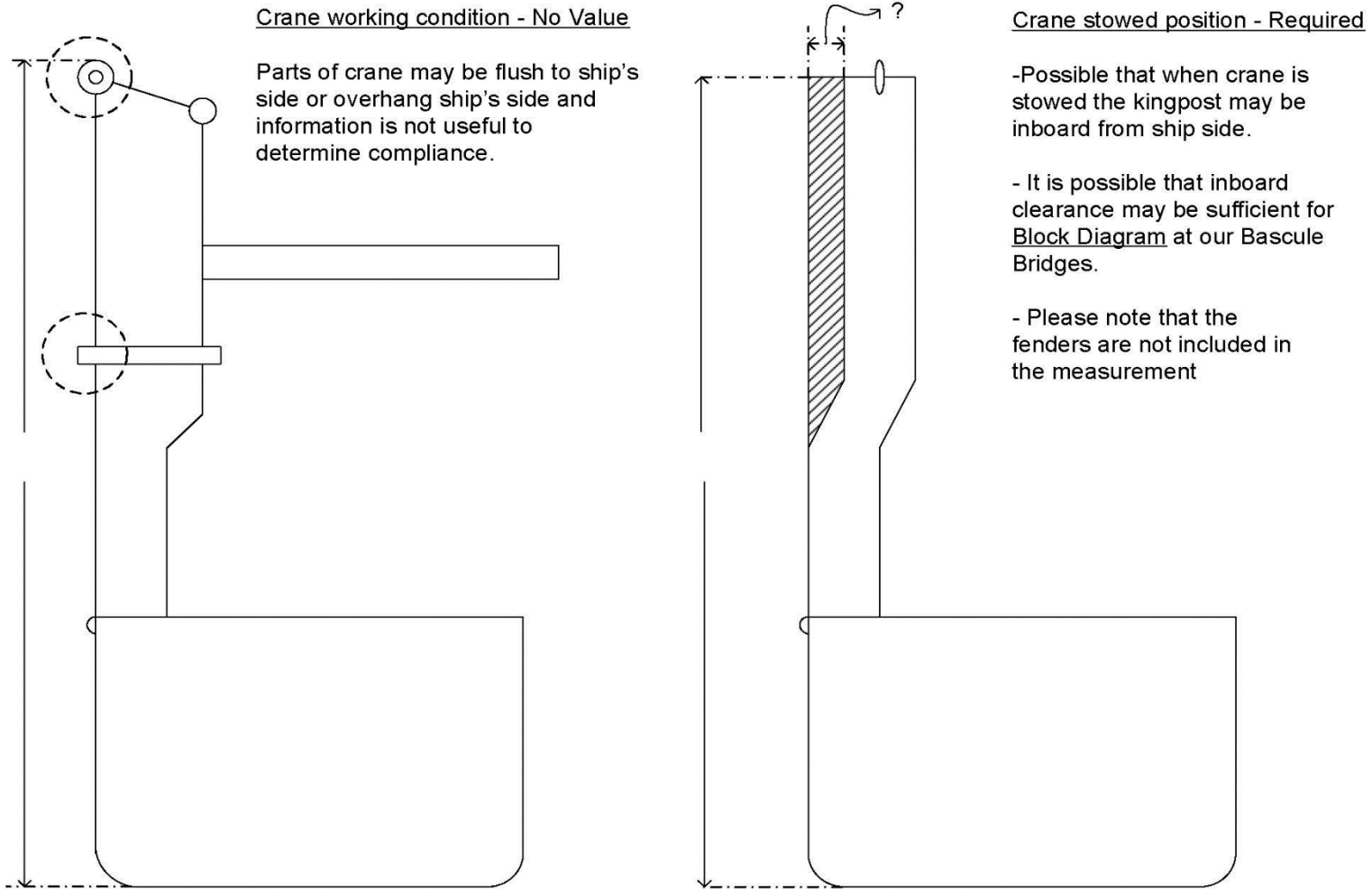

Refer to appendix 1 - Block Diagram in Seaway Handbook

marinoff/plan review/ dessin/dessin an/ crane stowed

c) Minimum Required Crane Measurements

29c - Minimum Required - Crane Measurements - Example

Crane: Critical height for Bascule bridges and Seaway Structures

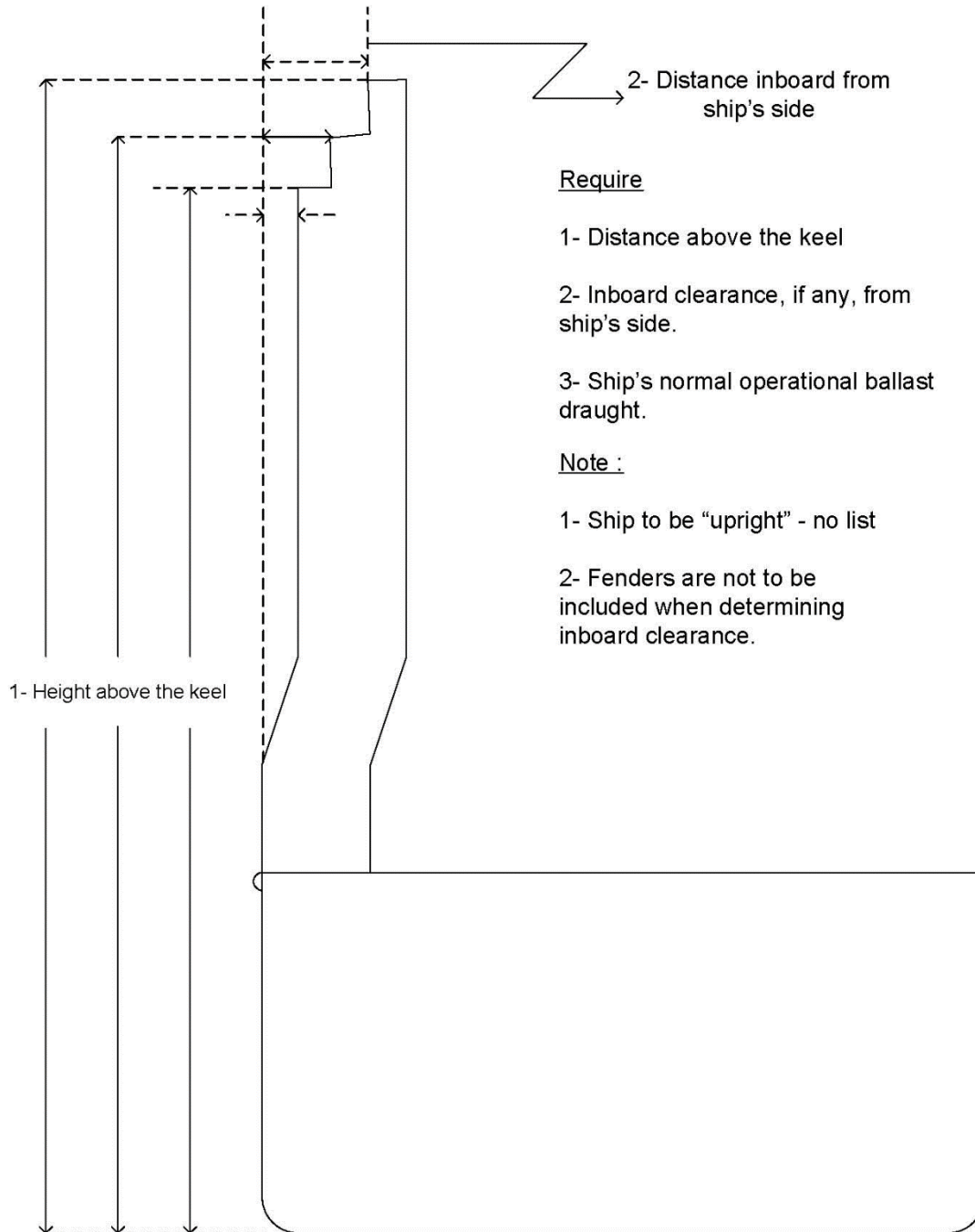

30. Ballast Water Tank Information

Reporting:

All ships entering the St. Lawrence Seaway/Great Lakes System shall comply with Seaway Ballast Water Regulations by following submission requirements of Transport Canada and U.S. Coast Guard by submission of the joint “St. Lawrence Seaway Ballast Water Reporting Form” contained in Transport Canada’s (TP13617E).

<http://www.tc.gc.ca/eng/marinesafety/tp-tp13617-menu-2138.htm>

Reporting Timelines:

Transport Canada requires submission of the ballast water information 96 hours before entry into the territorial sea of Canada at the following, by email to: atlanticballastwater@tc.gc.ca or, by facsimile: (902) 426-6657. Contact Number: (902) 426-4956.

U.S. Coast Guard requires submission of the ballast water information 24 hours before the ship arrives in Montreal, Quebec at the following, by facsimile: (315) 769-5032. Contact Number: (315) 769-5483.

Inspections:

All ships bound for a port within the St. Lawrence Seaway/Great Lakes System (System) (that originate outside the Canadian EEZ) will be subject to ballast tank inspection. On the ships initial transit into the System, the ballast tank inspection will be conducted on the ship’s first stop in a lower St. Lawrence River Port by Transport Canada, or during the ship’s Enhanced Seaway Inspection, by the Seaway, Transport Canada prior to entering the System.

Ballast tank inspections on subsequent transits of the System will be conducted at the first opportunity prior to entering the System or while in-transit or at rest within the Seaway System.

Masters shall ensure that at least one crew member is available to accompany inspection personnel so as not to result in undue delays.

Compliance:

Ships unable to conduct a saltwater flushing of their ballast tanks will follow the reporting procedures of Transport Canada and the U.S. Coast Guard. The Seaway Corporations will enforce “Conditions of Entry” in compliance with Transport Canada’s [Ballast Water Control and Management Regulations](#).

Ships found with non-compliant ballast tanks will be issued a retention letter by the appropriate agency(s) and will be subject to verification upon its outbound transit of the System.

NAVIGATION SIGNAL LIGHT SYSTEM (Canadian Locks)

1. General

A signal light system is provided at the approaches to all Canadian locks to inform the ship master of the situation in the lock as he approaches it. The system consists of a navigation signal light panel preceded by up to three limit of approach (L/A) signs located along the approach wall at each end of the lock, as shown in *Figure 1*.

The operating sequence is uniform throughout the system and is detailed in the following paragraphs. However, the number of L/A' s and the distances between them are subject to variations due to differences in the configuration of lock approaches.

In the Welland Canal, an L/A sign with signal lights similar to those at the locks is installed above and below the Guard Gate cut. These lights are operated from the Control Centre.

FIGURE 1



2. L/A Signs

The L/A signs are intended as an aid to the ship master in approaching a lock as promptly as possible. Their operation is as follows:

(a) *Limit of Approach No. 3*

The L/A signs are equipped with red navigation lights only, and are used:

- (i) as a distance marker only by a ship making a passing entry manoeuvre;
- (ii) as a mooring L/A for modified passing entry manoeuvre.

(b) *Limit of Approach No. 2*

The L/A signs are equipped with red navigation lights only, and are used:

- (i) by a ship waiting for the first stage of a dump or fill during a turnback lockage at locks where turbulence above or below the gates exists - see "Turnback Lockages - General".
- (ii) as a distance marker only by two ships executing a passing entry manoeuvre; (See Ship Manoeuvres)
- (iii) by a moored ship waiting for an outbound to pass, when a passing entry is not possible.

(c) *Limit of Approach No. 1*

The L/A signs are equipped with red and green navigation lights, and are used:

- (i) as a distance marker by a ship for which the lock is being turned back (final stage of dump or fill);
- (ii) as a mooring position at certain locks when the lock is being turned back in favour of the ship. (See Turnback Lockages).
- (iii) to indicate that the last piece of equipment at that end of the lock has started to open (lock gates, bridge or ship arrester as applicable) when the L/A 1 red lights start to flash.

The **RED LIGHTS** on the limit of approach (L/A) signs have two characteristics: Fixed or Flashing.

Under no circumstances should a ship pass an L/A sign displaying a RED SIGNAL.

In addition, a flashing L/A sign indicates that the lock is being readied and the ship should:

- (i) continue to approach, with caution, as it will be able to pass this L/A soon;

OR

- (ii) be prepared to cast off and move ahead to the next L/A sign displaying the navigation signal.

N.B. The flashing signal is used when an "opposing" ship is departing from a lock, and also to indicate a lock is turning back for you.

N.B. In the pool between the Upper and Lower Beauharnois Locks, an L/A and a light standard bearing twin red and green navigation lights only are located at each end of the pool to warn the ship master of the lock condition. The signal lights on the standard operate as follows:

- (i) Fixed Red - *"Do not pass this L/A"*
- (ii) Flashing Red - *"Gates will open shortly"*
- (iii) Green - *"Lock is ready for you"*

3. Lock Signal Light Panels

Lock signal light panels are prominently displayed at the end of each lock to assist ship masters in timing their ship movements for an optimum speed of entry. However, because of inherent limitations, no signal panels have been installed on the ends facing the pool between the Upper and Lower Beauharnois Locks and between the flight locks (Locks 4, 5 and 6) on the Welland Canal.

The purpose of the lock signal light panel is to indicate to an approaching ship the state of readiness of the lock. The mode of operation of the lights indicates the dumping or filling of the lock, whether one or more ship(s) is in the lock and whether the approaching ship will be handled next or held at the wall while the lock is turned back against it.

4. Operation of Signal Light Panels

a) *Red Lights*

The **RED LIGHTS** operate in conjunction with the associated limit of approach light system and have identical characteristics, namely:

- i) **Fixed Red** - "lock is occupied, do not pass illuminated L/A"
- ii) **Red Flashing Together** - "lock is occupied by one ship, do not pass illuminated L/A, but stand by to move into lock when outbound ship has passed you"

OR

"lock is turning back for you, do not pass illuminated L/A but stand by to move into lock"

- iii) **Red Flashing Alternately** - "lock is occupied by more than one ship, do not pass illuminated L/ A but stand by to move into lock when outbound ships have passed you"

NOTE: *L/A I will start to flash only after the last piece of equipment at that end of the lock starts to open (bridge, gates or ship arrester).*

b) ***Amber Lights***

In the Montreal/Lake Ontario section and the Welland Canal, each illuminated AMBER LIGHT indicates five (5) minutes of time while each flashing amber light indicates two and a half (2 ½) minutes of time.

Upbound ships will observe that, during the dump of a lock, the amber lights on the lower end navigation signal light panel operate as follows:

- Two steady amber lights are shown ten (10) minutes before the lock end is fully opened.
- One steady and one flashing amber light are shown seven and a half (7 ½) minutes before the lock is fully opened.
- One steady amber light shows five (5) minutes before the lock is fully opened.
- One flashing amber light shows two and a half (2 ½) minutes before the lock is fully opened.
- When the two amber lights are extinguished, the lock is fully opened and the ship can enter as soon as the green light is exhibited.

Downbound ships will observe that:

- During the fill of a lock, the amber lights on the upper end navigation signal light panel operate in the same manner as for the upbound ships.
- By counting the illuminated amber lights, it is therefore possible to determine the time until the lock is fully open in minutes.

At Locks 1 to 7 inclusive, in the Welland Canal, the light timing sequence makes use of only two amber lights as follows:

- Two steady amber lights are shown ten (10) minutes before the lock end is fully opened.

- One steady and one flashing amber light are shown seven and a half (7 ½) minutes before the lock is fully opened.
- One steady amber light only shows five (5) minutes before the lock is fully opened.
- A single flashing amber light shows two and a half (2 ½) minutes before the lock is fully opened.
- When the two amber lights are extinguished, the lock is fully opened and the ship can enter as soon as the green light is exhibited

c) **Green Lights**

GREEN navigation lights work in conjunction with the green lights on L/A 1 and their only characteristic is:

Fixed green - "lock is ready for you - enter as promptly as possible".

SHIP MANOEUVRES (Canadian Locks)

1. General

Two prime factors in providing efficient ship transits are the reduction of "dead time" at a lock, which is that period between the exit of one ship from a lock and the entry of another, and the elimination of the need to tie up at the approach walls. With the increase in traffic, new Control Centre facilities and procedures, and additional aids to navigation, it is desired to make much greater use of the "passing entry" procedures as described hereunder, when two ships meet immediately outside a lock and when weather conditions permit.

2. Passing Entry

Ideally, to execute the "passing entry" the ship approaching the lock should be 450 m to 915 m from the end of the approach wall when the lock starts to dump or fill. This distance allows for variations in ship speed. At this point, the navigation lights and L/A 3 are fixed red. The amber lights come on with the start of the dump or fill (*Figure 3*).

FIGURE 3

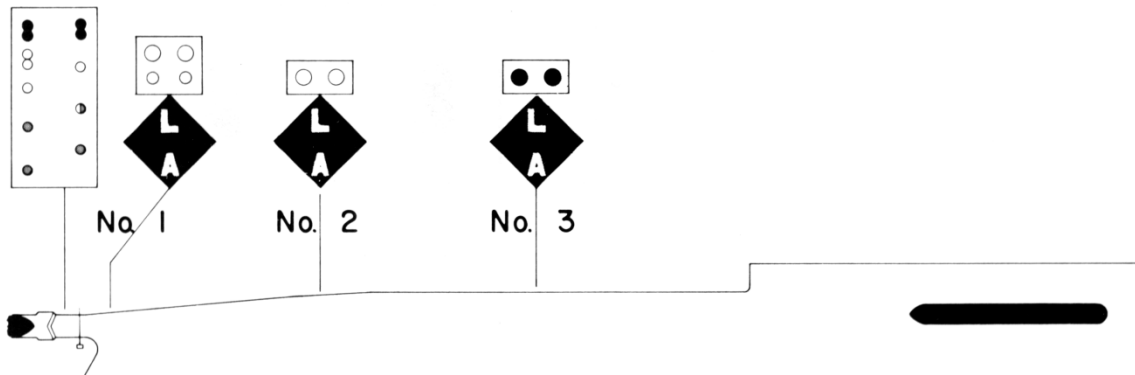

When the lock gates open, the navigation lights on L/A 3 begin to flash. As the ship in the lock casts off, L/A 3 is extinguished and L/A 2 starts to flash. At this time, the inbound ship should be at the end of the approach wall (*Figure 4*).

FIGURE 4

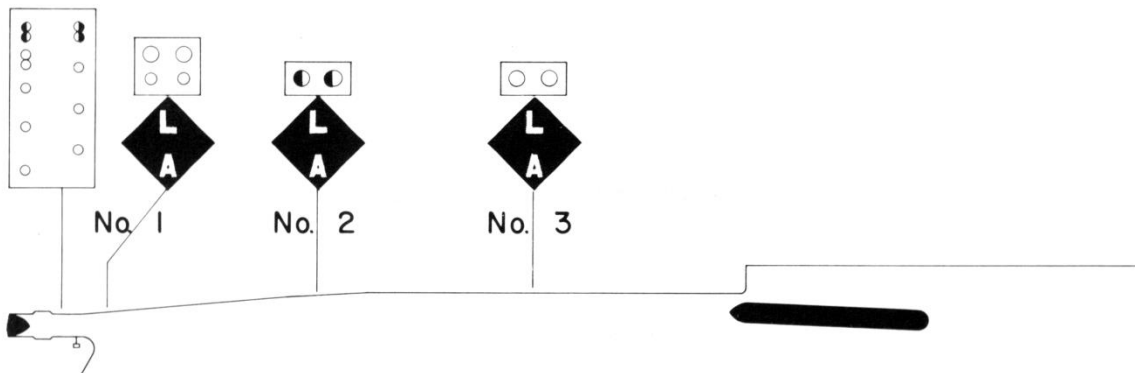

As the stern of the last outbound ship clears the lock, L/A 2 is extinguished and the green lights are shown on the navigation panel and L/A 1. The bow of the inbound ship should be at L/A 3 at this time (*Figure 5*).

(See variation below, when a road bridge is involved)

FIGURE 5

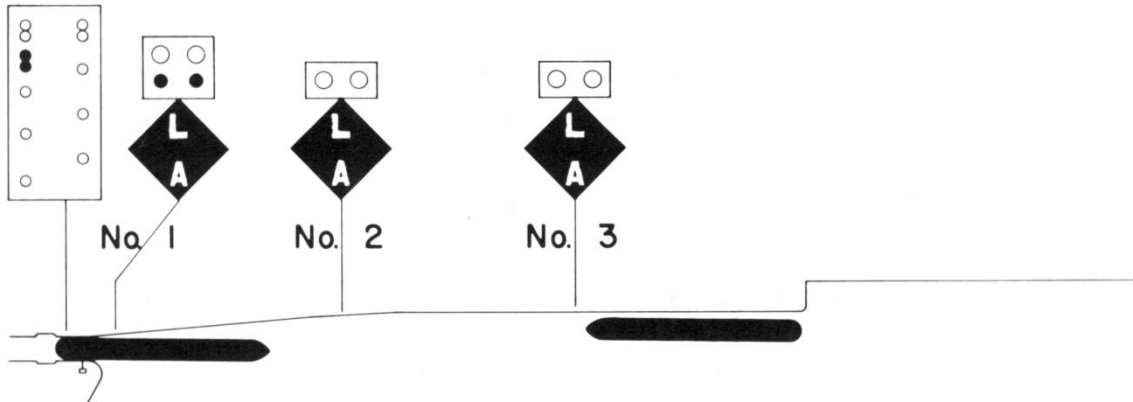

As the ships continue to approach each other, the ideal meeting point is when the bow of the inbound and the stern of the outbound are abeam of L/A 2 (Figure 6).

FIGURE 6

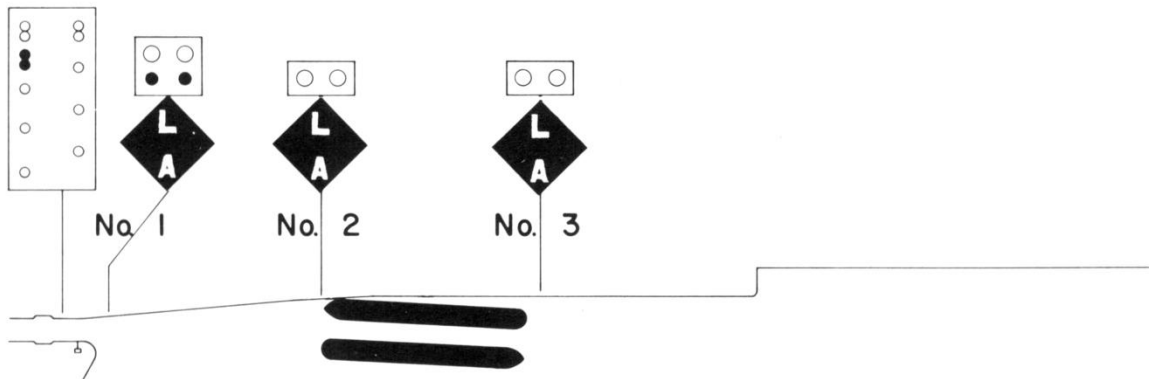

Experience, confirmed by theoretical calculation, proves that the inbound ship moving along a wall faces much less suction from the outbound than it does if moored at the wall.

When the ships have passed each other, the inbound ship continues into the lock as smartly as is prudent and possible.

3. Modified Passing Entry

In cases where a ship is obviously going to reach a wall well in advance of the outbound ship leaving the lock, the inbound ship will moor at L/A 3.

When the lockage in progress has completed its dump or fill and the end of the lock is completely open, the red navigation lights and the L/A 3 begin flashing and the inbound ship prepares to cast off, the outbound ship at this time will be casting off and moving out of the lock.

Immediately upon completion of the outbound ship casting off (i.e. the last ship in the case of a tandem lockage) the L/A 3 flashing lights will be extinguished and the L/A 2 flashing lights will come on.

The inbound ship should then commence entry to ensure that its bow is abeam of L/A 2 at the time the stern of the outbound ship is abeam this same L/A.

NOTE: The green lights on L/A 1 and the lock navigation lights will be activated when the stern of the last outbound ship has cleared the lock chamber.

4. Passing Entry Where a Road Bridge Crosses Over One End of a Lock

When the bridge remains up between exit and entry of ships, the sequence will be as described above for the Passing Entry. However, when it becomes necessary to lower the bridge between the times of exit and entry, the sequence is modified as follows:

As the lock fills or dumps, the outer L/A and navigation lights are fixed red with the time remaining indicated by the amber lights. The approaching ship is then at some distance from the L/A 3 as shown in Figure 7.

FIGURE 7

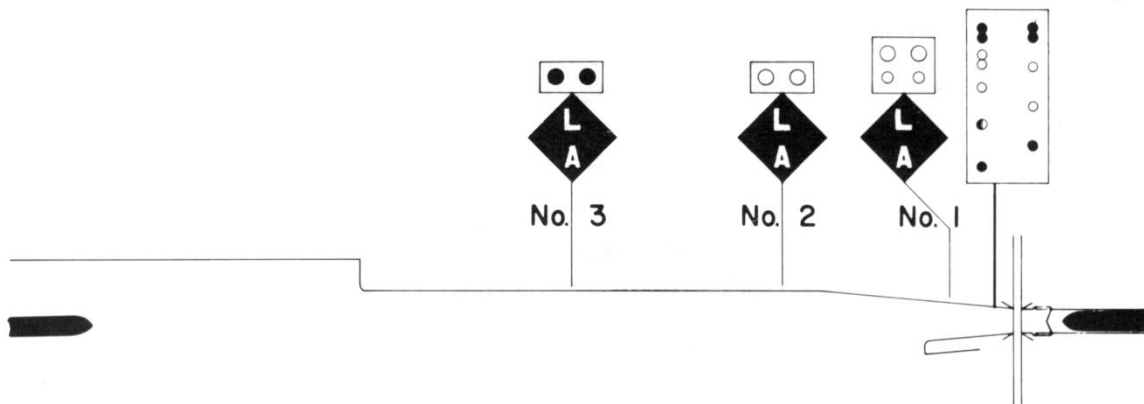

When the lock gates open, the navigation lights and L/A 3 begin to flash. As the ship in the lock casts off, L/A 3 is extinguished and L/A 2 starts to flash, which indicates that the inbound ship shall prepare to proceed to L/A 1, or stand by to cast off and move along the wall (Figure 8).

FIGURE 8

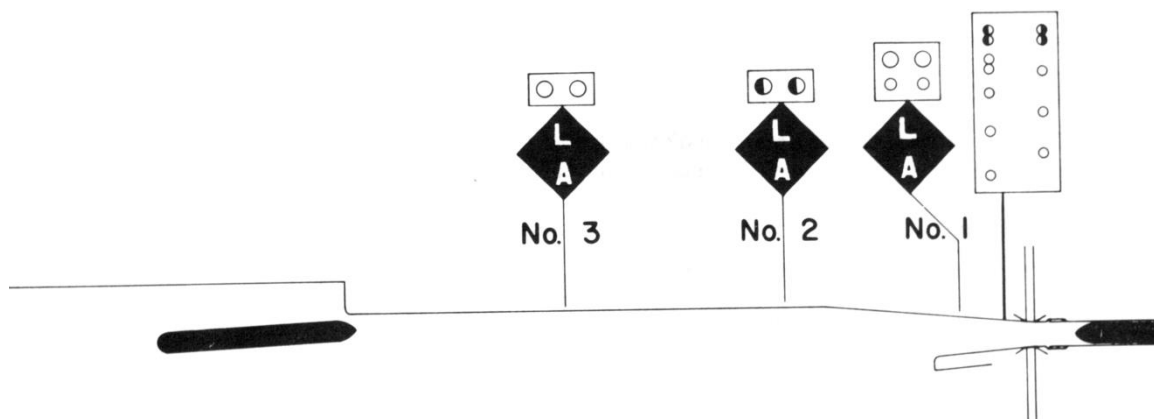

As the bridge is lowering behind the outbound ship. L/A 2 is extinguished, L/A 1 commences flashing red and goes to steady red once the bridge is fully lowered, indicating that the ship may approach but not pass this point (Figure 9).

FIGURE 9

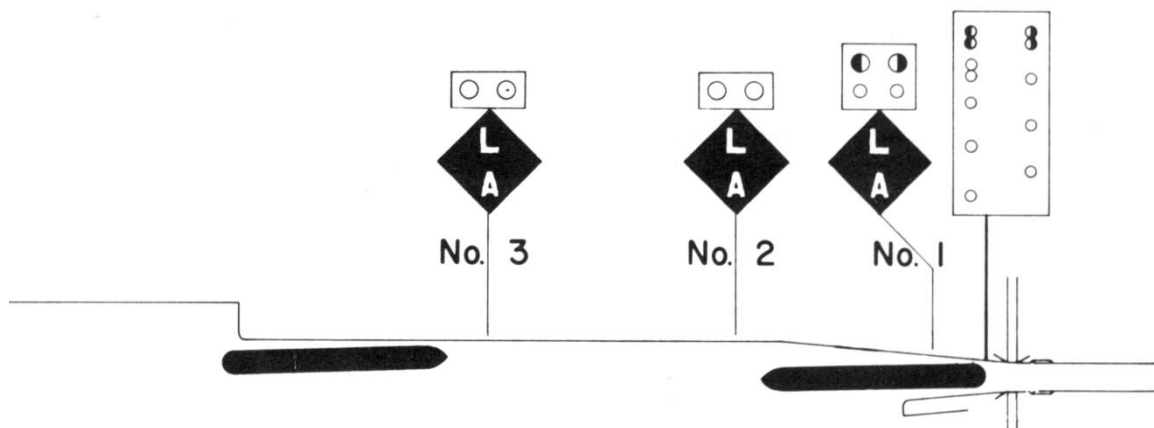

TURNBACK LOCKAGE (Canadian Locks)

1. General

In the execution of turnback lockages where water turbulence is a problem in the vicinity of lock gates, provisions have been made for the automatic transfer of flashing red lights from L/A 2 to steady red lights on L/A 1 as follows:

| | | | |
|------------------|-----------|---|----------------------------------|
| Eastern Section: | Upper end | - | 3 minutes before upper end opens |
| | Lower end | - | 6 minutes before lower end opens |
| Western Section: | Lower end | - | 5 minutes before lower end opens |

This automatic transfer serves to prevent a ship approaching too close to the lock gates until the turbulence has subsided to an acceptable level.

2. Turnback for Upbound Ships

The above features have been provided for upbound ships at the following locations:

- a) St. Lambert Lock
- b) Côte Ste. Catherine Lock
- c) Lower Beauharnois Lock
- d) Lock 1 - Welland Canal
- e) Lock 2 - Welland Canal
- f) Lock 3 - Welland Canal
- g) Lock 4 - Welland Canal

NOTE: 1) *At Lock 4, the automatic transfer takes place nine (9) minutes before gates open.*

2) *At St. Lambert Lock, the automatic transfer takes place four (4) minutes before gates open.*

At these locations, masters may observe the following prior to a turnback:

- a) Red flashing navigation lights - "will turn back for you"
- b) Red fixed on L/A 2 - "dump not started, do not pass this L/A"

- c) Six (6) minutes (Eastern Section) or five (5) minutes (Welland Canal) before gates are fully opened, the following is observed: red navigation lights continue flashing, amber lights are operating and steady red signals on L/A 1 are displayed. L/A 1 will start to flash when the last piece of equipment at that end of the lock starts to open (lock gates, bridge or ship arrester as applicable).
- d) When lock is fully opened:
 - the navigation lights and L/A I show fixed green.
 - "the lock is ready for you, enter as promptly as possible".

3. Turnback for Downbound Ships

The automatic transfer of red flashing lights (3 minutes before gates open) from L/A 2 to L/A 1 has been provided at the following locations:

- a) St. Lambert Lock
- b) Côte Ste. Catherine Lock
- c) Upper Beauharnois Lock

The display of lights to waiting ships is the same as that described in the preceding paragraph for upbound ships except for the difference in timing.

At all other locations when the lock is being turned back to receive the inbound ship, the following is observed:

- a) Lock navigation signal lights and the signals on L/A 1 display flashing red and, during the dump or fill, the amber lights are operating.
- b) Since the ship is already at the nearest L/A to the lock, and turbulence does not cause any problem, no move is necessary until the lock is fully open, at which time the navigation and L/A signal lights show fixed green.

MOORING SHIPS (Canadian Locks)

1. Safety Precautions

To prevent accidents on lock walls, especially those that could be caused by breaking mooring wires, Seaway linesmen have been trained in the safe handling of mooring wires and in the proper hand signals to be used when working with ship crews.

At all Canadian locks the standard hand signals as shown hereunder will be used during the ship mooring operation.

STOP



EMERGENCY STOP



SLACK

Safety Rules:



1. Always slack mooring wires as required.
2. Avoid giving too much slack.

HEAVE

Safety Rules:



1. Never heave on a mooring wire until the lock crew member gives the hand signal.
2. For their own safety, the lock crew members will always get well clear of mooring wire before giving signal to heave.
3. Always use slow speed to heave up wire when slack.

2. Mooring Lines

The length of the eye of a wire mooring line must be 2.44 metres and for a synthetic line 1.83 metres measured from the splice to the extreme end of the eye (see drawing).

NOTE: The table of breaking strength of mooring lines as given in Seaway Practices and Procedures no. 10 is expressed in metric tonnes. For comparison 9.8 KN is equal to one metric tonne (2204.6 lbs).

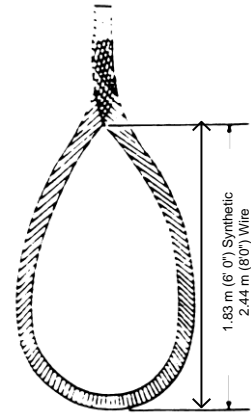

3. Ship Mooring Locations

The ship mooring locations at Canadian locks in the Seaway system have been standardized as much as possible.

The following table shows the targeted position of the ship's stem in the lock for each ship length category.

| Ship Length | <i>Ship Mooring Position (Stem at Lock Wall Marker)</i> |
|-------------------------------------|---|
| 211.00 m - 222.5 m (692' - 730') | "stop" marker |
| 202.00 m - 210.99 m (663' - 692') | 5 m marker |
| 185.00 m - 201.99 m (607' - 663') | 10 m marker |
| 145.00 m - 184.99 m (476' - 607') | 25 m marker |
| 105.00 m - 144.99 m (344' - 476') | 50 m marker |
| less than 105.00 m (less than 344') | 75 m marker |

Mooring positions are the same for upbound and downbound lockages.

Exceptions:

The table does not apply

- (1) at Lock 8, Welland Canal
- (2) where Final Mooring Position (FMP) adjusted to accommodate Hands Free Mooring (HFM) pad attachment
- (3) multiple lockages at all locks
- (4) ships with OAL greater than 222.5 (730')

For these exceptions ships will be moored as directed by the lock operator.

Where equipped at the Canadian locks, a Vessel Self Spotting System (VSS) will display to a qualified ship its distance to go before reaching the ship's designated Final Mooring Position (FMP). VSS will display 0 when the bow of the ship is at its designated FMP, regardless of where that is in the lock.

AMERICAN LOCKS

1. Navigation Signal Light System

Lock Traffic Lights:

The upstream lock traffic light panels at both the Snell and Eisenhower Locks are located on forty-foot towers on the guide wall near the upstream control buildings.

The downstream lock traffic light panels at both locks are located on the face of the concrete wall immediately below the downstream control buildings. These lights operate as follows: (*Figure 10*)

- | | |
|---------------------|--|
| SOLID RED | - Stop; lock not ready for ship. |
| FLASHING RED | - Lock is being prepared for ship. |
| GREEN | - When lock is clear, proceed. Lock is ready for entry. |

FIGURE 10

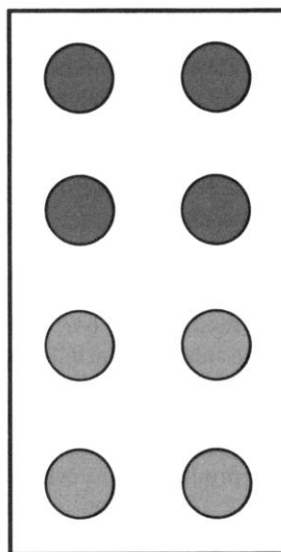

2. Tie-up Walls

a) *Length of Lock Walls*

Eisenhower Lock:

Upstream Wall - Heading 268° - 088° true
L/A 1 to end of wall358 m
L/A 2 to end of wall319 m

Downstream Wall - Heading 253° - 073° true
L/A 1 to end of wall250 m
L/A 2 to end of wall211 m

Snell Lock:

Upstream Wall - Heading 269° - 089° true
L/A 1 to end of wall246 m
L/A 2 to end of wall208 m

Downstream Wall - Heading 251° - 071° true
L/A 1 to end of wall461 m
L/A 2 to end of wall422 m

b) *Berthing Stations*

There are two (2) berthing stations located on the upper and lower tie up walls at each American lock. These are the limits of approach and there are signs labeled "Limit of Approach No. 1" (L/A-1) and "Limit of Approach No. 2" (L/A-2) on each wall. Ships with a beam of 18.3 m or less shall tie up at L/A-1 and ships with beams between 18.3 m and 23.8 m shall tie up at L/A-2.

c) *Lock Gate Assembly Area*

A lock gate assembly area is located at the end of the downstream guide wall at Eisenhower Lock. This facility enables the emergency assembly and later installation of spare downstream gate leaves at Eisenhower Lock in the event that the installed lock gate leaves are severely damaged. Components of the new facility include a slip, bulkhead wall, two (2) assembly towers and pads and a steel sheet pile cell at the end of the existing downstream guide wall. Ship masters and pilots are advised to approach the downstream guide wall with caution to avoid entering the slip area.

**APPENDIX 1
SEAWAY MILEAGES TO PRINCIPAL LOCATIONS**

Appendix I indicates distances from the origin of the Seaway to Long Point, on Lake Erie, broken down as follows:



- Montreal/Lake Ontario Section (*Origin of Seaway to Cape Vincent*)
- Lake Ontario (*Cape Vincent to Breakwater, Port Weller*)
- Welland Canal (*Breakwater, Port Weller, to Long Point*).

Distances are expressed in nautical miles

MONTREAL/LAKE ONTARIO SECTION

| MILE (nautical) | LOCATION |
|-----------------|---|
| 0.0 | Origin of Seaway - across from Laurier Pier, Montreal Harbour |
| 0.8 | CIP 2 |
| 2.8 | St. Lambert Lock |
| 10.3 | Côte Ste. Catherine Lock |
| 14.6 | Kahnawake Bridge |
| 27.5 | Lower Beauharnois Lock |
| 28.4 | Upper Beauharnois Lock |
| 33.8 | St. Louis Bridge |
| 38.8 | Valleyfield Bridge |
| 72.4 | Snell Lock |
| 75.6 | Eisenhower Lock |
| 97.9 | Iroquois Lock |
| 161.2 | Cape Vincent |

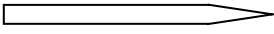
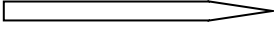
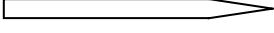
LAKE ONTARIO

| | | MILEAGE (Nautical Miles) | |
|-------------------------|---|---------------------------------|------------------|
| | | <u>Upbound</u> | <u>Downbound</u> |
| Cape Vincent |  | 41.1 | 43.0 |
| Sodus Point |  | 27.7 | 28.7 |
| Mid-Lake Ontario |  | 33.6 | 32.9 |
| Newcastle |  | 37.5 | 35.8 |
| Breakwater, Port Weller |  | 139.9 | 140.4 |
| TOTAL | | | |

WELLAND CANAL

| MILE (nautical) | LOCATION |
|-----------------|-----------------------------|
| 0.0 | Breakwater at Port Weller |
| 1.7 | Lock 1 |
| 3.2 | Lock 2 |
| 4.9 | Bridge 4 |
| 5.5 | Lock 3 |
| 6.8 | Locks 4, 5, 6 |
| 7.5 | Lock 7 |
| 8.3 | Guard Gate Cut |
| 9.2 | Former Bridge 10 Piers |
| 10.4 | Bridge 11 |
| 21.2 | Lock 8 |
| 21.9 | Bridge 21 |
| 23.5 | Breakwater at Port Colborne |
| 26.1 | CIP 16 |

Distance between CIP 16 and Long Point - Upbound 38.2
 - Downbound 39.1

**APPENDIX 2
TABLE OF TRUE ORIENTATION - Canal Locks**

The table indicates true bearings of locks in the St. Lawrence Seaway for ships proceeding upbound.

| MONTREAL/LAKE ONTARIO | | WELLAND | |
|-----------------------------------|------------|---------------|------------|
| St. Lambert Lock | 167°46'30" | Lock 1 | 164°23'00" |
| Côte Ste. Catherine Lock | 270°02'00" | Lock 2 | 156°26'00" |
| Upper and Lower Beauharnois Locks | 203°44'22" | Lock 3 | 174°25'30" |
| Snell Lock | 260°18'55" | Locks 4,5 & 6 | 183°10'30" |
| Eisenhower Lock | 260°18'55" | Lock 7 | 190°08'46" |
| Iroquois Lock | 205°49'00" | Lock 8 | 189°50'32" |

APPENDIX 3 Free Drawing Review Service

The St. Lawrence Seaway Management Corporation will review at no cost ship's plans of new buildings, as well as those of ships arranging a first voyage.

Plans should include the following documents:

- General Arrangement
- Lines Plans
- Forward and aft mooring arrangement
- Anchor arrangement
- Fender arrangement
- Cross Section - in way of Superstructures / Cranes
- Normal operating ballast draughts

Ships plan packages should indicate "**no commercial value**" and can be sent to:

Marine Services
The St. Lawrence Seaway Management Corporation
202 Pitt Street
Cornwall, Ontario
K6J 3P7
Tel: (613) 932-5170,

Alternatively, electronic plans/drawings to scale can also be sent to sismcmarineservices@seaway.ca.

APPENDIX 4 - Hand Lines

Reference: Practices &
Procedure, Regulation
13

No. required: 4
Thickness: Uniform 12-18mm diameter
Length: 30 meters each
End: Back splice or taped
Eye splices & weights are not permitted.

Securing Hand Lines to Mooring Lines/Wire Ropes

(1) Upbound Vessels

When transiting upbound into the St. Lawrence River and Great Lakes, and whenever the ship is lower than the personnel at the lock, hand lines will be passed by the lock personnel (see note below regarding Iroquois Lock in the MLO Section and Lock #8 in the Welland Canal).

Once received, hand lines are to be secured to the ship's mooring lines by means of a CLOVE HITCH knot, approximately 60 cm behind the eye splice (see Illustration A).

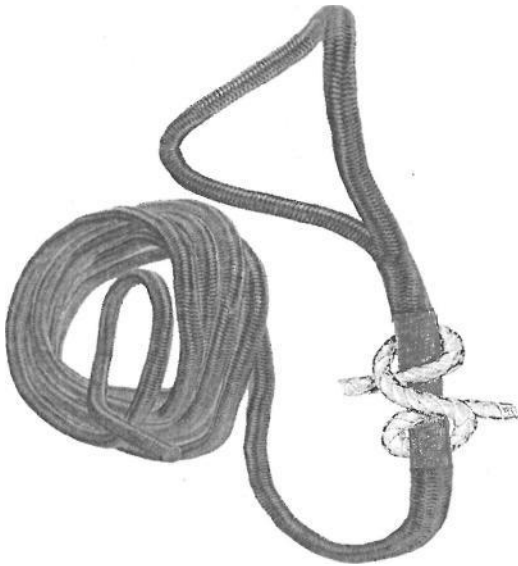
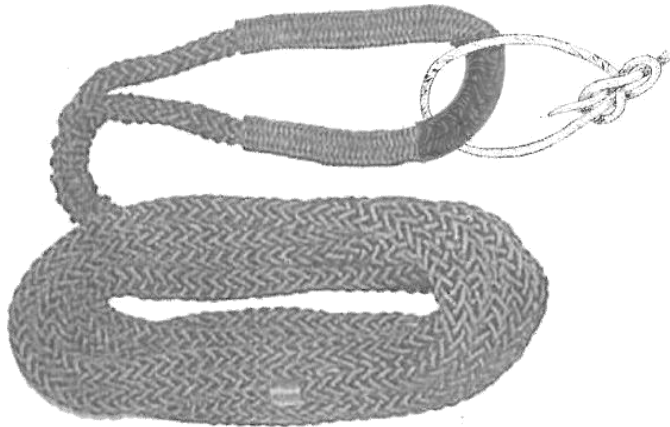

Illustration A: Clove Hitch behind eye splice.

Note: At Iroquois Lock and Welland Canal Lock #8, since the amount the vessel will be raised or lowered is minimal, vessels will arrive higher than shoreside personnel. For this reason, ships will follow instructions within step 2 below for passing and securing hand lines.

(2) Downbound Vessels

When transiting downbound out of the Great Lakes and St. Lawrence River, and whenever the ship is higher than personnel at the lock, hand lines will be passed by the ship's crew to lock personnel using the ship's hand lines.



Hand lines are to be secured to the ship's mooring lines by means of a BOWLINE knot, within the eye splice (see Illustration B at left).

Illustration B: Bowline within the eye splice.